

Actual Trends in Crane Automation – Directions for the Future

Oliver Sawodny

Full Professor
University of Stuttgart
Institute for System Dynamics

Jörg Neupert

Research Associate
University of Stuttgart
Institute for System Dynamics

Eckhard Arnold

Research Associate
University of Stuttgart
Institute for System Dynamics

In industrial practice rope guided handling systems are state of the art. But, in fact, even in the case of skilled operators and increased handling capacity still the human operator is competitive enough to prevent the overall use of automation systems. In the talk, the state of the art of automated cranes is reflected. At the example of a long lasting cooperation with LIEBHERR the automation concept for rotary cranes is presented. The requirements for the sensor and actuator systems are discussed. Especially, the sensor system for the rope angle is a critical point. Different sensor systems are presented and compared. For the actuators, requirements concerning the necessary dynamical behaviour are discussed. The control concept is introduced and the efficiency is shown in measurement results and video presentations. The control concept uses mainly two important methods in control theory. After a brief introduction into the theory of flat systems and the model predictive approach as a tool for the generation of feasible trajectories the way how to apply these to the automation system for a rotary crane is presented. The directions for the future will be derived discussing the question of further improvement of crane systems.

Keywords: crane automation, crane control, boom cranes, anti-sway systems for cranes.

1. INTRODUCTION

Especially in case of high weights, rope guided material handling systems are most effective to transfer a load within a defined workspace. During the development over the last decades depending on the freight, which has to be handled, the transfer distance, the weight, and the frequency of use, specific classes of cranes has been established. Most important classes are suspension cranes, bridge girder cranes, portal cranes, gantry cranes, and different types of rotary cranes as tower cranes, boom cranes etc.

For several decades efforts have been taken to automate the handling processes by cranes. First systems started in the 70th, applying optimal control ideas for the feed forward control of gantry cranes [1-3]. Very soon it was observed that time optimal solutions are not robust enough for a safe handling of the material. During the next steps, control concepts with feedback of the rope angle were introduced [4-6]. The main challenge was to find a robust and reliable measurement system with the necessary precision. For the last 20 years many different solutions were introduced. Two main directions have been established in the last years. The first one is the measurement of the rope angle by encoders by a cardanic joint (Fig. 1). The second are vision based systems [7].

In case of cranes operating in the Cartesian coordinate systems these preconditions automation systems with anti-sway functionalities became state of

the art. Even in the case of larger crane systems with investment costs over half a Million Euro, e.g. for harbour cranes, anti-sway functionalities for the crane control are more and more common. But, for smaller facilities automated functionalities including anti-sway are not standard. Surely, a reason to operate the crane manually is that automated systems with anti-sway functionalities have some disadvantages. For the fully automated mode it is needed that for the automated crane operation it is strictly forbidden to enter the area of the crane during the automated operation. That means, in addition to the transportation process, the handling process to pick up the load and to deliver at the desired target point needs to be automated (Fig. 2) [6,8].

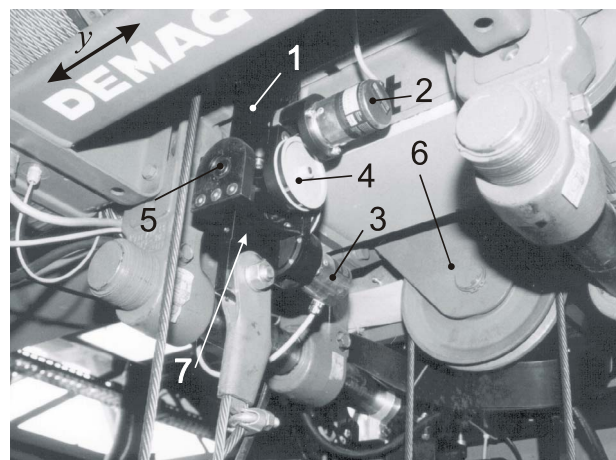

Figure 1. Cardanic joint to measure the rope angle installed in a 5 t-bridge crane

Very often this is a complex task. In addition the automation of these processes needs specific solutions depending on the specific type of load to be handled. As a conclusion only in very rare cases cranes for material

Received: October 2009, Accepted: November 2009
Correspondence to: Dr-Ing. Oliver Sawodny
Institute for System Dynamics, University of Stuttgart,
D70550 Stuttgart, Germany
E-mail: sawodny@isys.uni-stuttgart.de

handling are running in a fully automated mode. More often crane systems with anti-sway functionalities are found in so called semi-automated operation. Semi-automated operation modes still need a human operator who is supervising the operation of the crane. This means you still need an operator which will lead to higher operational costs. Therefore, the break even point of the investment is higher and cost effectiveness lower.



Figure 2. Example of automated handling of pallet boxes by a rope guided material handling system [6]

In case of these facilities it can be distinguished between an operation mode where under the supervision of the human operator the crane automatically is running from position A to position B and between an operation mode where the human operator is operating the crane by hand levers. In industrial practice especially the second type of cranes are found frequently. For these cranes, crane operators need to have a good a feeling at the hand levers for the operation of the crane. This is a challenge for a crane with an automated anti-sway system. Very often anti-sway systems are here criticized by the human operators because of a long follow-up movement especially when the operator gives an immediate stop command after the crane already had reached the full speed. In addition, skilled crane operators criticize slow acceleration of the crane with activated anti-sway system after he commands the acceleration towards maximum velocity.

In the given talk the focus is on slewing cranes as a not typical application field of anti-sway systems. In the following the system itself will be introduced in detail, the sensors/actuator system discussed, and the control system introduced. Specially, the before given disadvantages of anti-sway systems are addressed in the following presented control concept.

2. SLEWING CRANE LIEBHERR LHM

In the following a boom crane a specific type of rotary crane is considered. The crane is a harbour mobile crane for mixed freight in smaller or mid-sized harbours (Fig. 3) [9].

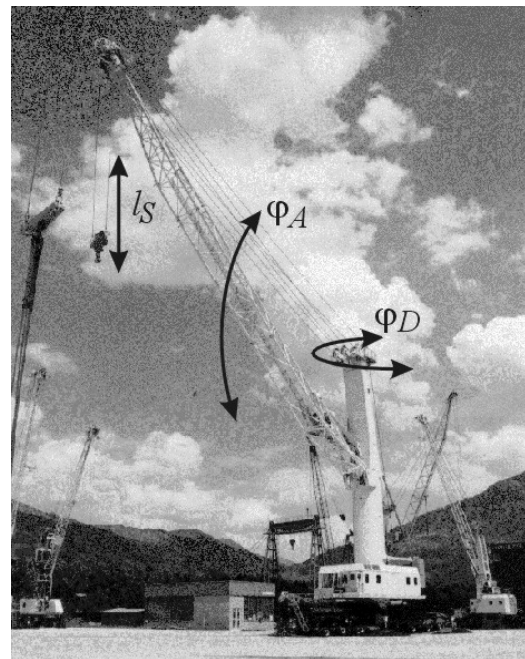

Figure 3. Liebherr LHM Harbour Mobile Crane

This means the crane can be used for bulk handling as well as for container handling or general cargo load. For that purpose the crane hook can be equipped with several different grippers. In comparison to the standard gantry cranes in harbours, the harbour mobile crane is able to move on 64 tyres flexible from one position to the next and needs no rail mounted on the pier. With a boom which allows loading up to 50 t at an outreach of more than 50 meters it is even able to handle the super panamax ships. The crane is equipped with an installed diesel engine of 600 kilowatts and is able to hoist with a velocity of 1.5 meters per second. All drive systems are hydraulic drive systems including hoisting. The luffing of the boom is operated by a hydraulic cylinder mounted between crane tower and boom. All hydraulic drive systems are closed systems and each hydraulic circuit is operated by a separate pump at the power divider gear box. The crane can be operated by a crane cabin 25 meters above the pier with a good visibility on the ship or by a crane cabin down at the engine house in case of moving the crane on the pier. The cabin provides hand levers for the operation of the crane which deliver the signal directly to the central control unit via a CAN bus. The central control unit connects all the other inferior hardware systems like the monitor system e.g.. By CAN bus all sensor and actuator signals are connected to the central control unit. For the control system the following sensors are provided. To measure the slewing position of the crane tower, the position of the winch respectively the rope length, the position of the boom respectively the outreach of the boom tip, encoder systems are installed. The resolution of the encoders is calculated to reach a control performance of a few centimetres concerning to the position accuracy of the crane load. In order to limit the maximum torque on the mobile crane, a load cell is installed to measure the actual crane load. The system is integrated in the winch, measuring in fact the force on the rope. All these sensors are standard equipment and not specially installed for the anti-sway system.

The only remaining sensor system which needs to be installed in addition is the sensor to measure the rope angle. In case of a boom crane with rope length of up to 85 meters, vision based systems are critical to use because the vision systems need to be adjusted in the direction of the view on the crane hook depending on the moving boom. Therefore, the installation of the boom tip is not adequate. To use the crane tower as location for the sensor is also difficult, because the load cannot be seen in some scenarios. Mechanical systems as cardanic joints with encoders are also quite critical as the resolution needs to be very high to have at the end a position accuracy of less than 10 cm in case of a rope length of more than 60 meters. Therefore, in case of the Liebherr harbour mobile crane a gyroscope was used to measure the rope angle velocity. In the meantime these sensors have a sufficiently high resolution and are able to be operated under very rough conditions. As these sensors came out of the aerospace and aircraft industry, specifications are very often over temperature ranges from minus 50 degrees up to plus 85 degrees including high robustness concerning to shock and other stress situations. Now in automotive applications these sensor systems came on the market for extremely low cost. Analog Devices Inc. is now selling these sensors for a few dollars. In case of using gyroscopes the effort for the evaluation of the rope angle is quite high as the offset of these sensors needs to be compensated and the effect of higher oscillation modes on the measurement signals has to be eliminated.

3. PRINCIPLES OF CONTROL FOR CRANES AS FLEXIBLE MANIPULATORS

To control the crane is a well treated problem in control engineering even from the point of view of the educational side [10]. In spite of that fact, it has not been established in industrial practice. Some of the reasons for that have been introduced already in Section 2. Beside the feasible sensor system the different dynamic behaviour concerning to the control operator, if the operator is running the crane by handlebars with activated anti sway system, is a main problem. The question will be, can the control be designed in a way that the operator has the advantage of the anti-sway functionalities but still the chance to influence the crane directly to prevent that he feels unsafe because of a long lasting follow-up movement. In order to address these questions an overlook about the different control concepts in the context of automatic cranes will be given.

From the theoretical point of view, a crane can be assumed as a flexible link manipulator resulting in standard equations of motion with an inertial matrix, a vector of coriolis and centripetal terms, and the vector of the gravitational forces. It is clear that the comparison is not exactly true because a crane is in fact a rope guided manipulator which results in different approaches for the rope starting from a complex approach by partial differential equations to simple spring-damper approximations. From a systems theory point of view the problem becomes simpler if a cartesian coordinate system is introduced and the

movement is parallel to this cartesian coordinate system because the system in that case is decoupled. Of course, the simple pendulum equations in case of a concentrated parameter approach are still resulting in nonlinear equations. But, in fact, if you look at a crane system with rope angles less than 30 degrees, the linearization is still a good approximation for the dynamic system behaviour. From that point of view the simplest concept to realize a control system is to look at the Cartesian representation of the system which we will find e.g. in a bridge crane or gantry crane and to realize then a decentralized control concept concerning to the different movement directions based on a linearized system representation.

What is a solution in case of a slewing crane, where we have in fact a cylindrical coordinate system for the different movements which means that we have to take dominant nonlinear terms into account. Especially the term of the centripetal forces in case of turning results in a radial movement of the load depending on the square of the slewing velocity. In that case one feasible concept is still to apply the decentralized principle for the control to compensate the nonlinear effect by a feed forward term to cancel out the effect partially [11] (Fig. 4).

Of course, there are model errors depending on coriolis terms but these can be assumed to be compensated by the feedback loop of the control loop of the radial movement.

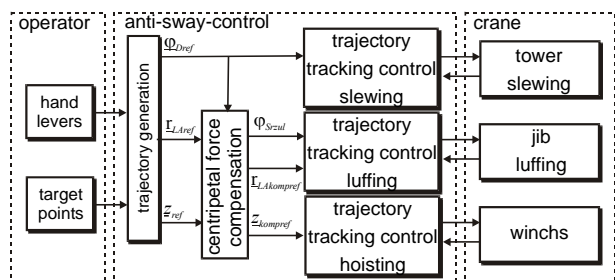

Figure 4. Decentralized control approach with feedforward term to compensate nonlinear centripetal terms

Up to that point we have a sufficient solution by linear control concepts, but if you look on our system like the Liebherr harbour mobile crane we have nonlinear kinematics for the luffing movement by the hydraulic cylinder which is mounted between crane tower and crane boom. How should we treat that problem? Here nonlinear methods need to be applied.

In the 80th the input output linearization technique was developed [12]. Input-Output linearization is a method out of nonlinear control, where you derive a nonlinear unique transformation for the system, which enables you to transform the system into a linear coordinate system. For this method the assumption needs to be fulfilled that we have an input affine system which means a linear dependency on the input variable. In case of the Liebherr crane although the hydraulic cylinder is described by a dominant nonlinear behaviour we can assume an input affine system and are able to apply the methods of input output linearization for that problem [13].

These methods become generalized by the development of the so called flat system theory in the 90th [14]. For the flatnessbased approach the assumption

of an input affine representation is not longer needed. For the definition of flat systems an analytical expression of the flat outputs and their derivatives concerning to the state and input vector is necessary. In both cases behind this representation is a transformation, which will bring the nonlinear system by an inverse system representation into a form of an integrator chain concerning to the different outputs. In the combination of nonlinear system plus inverse system representation this results then in a linear system representation. This trick enables then to apply again linear control technologies on the problem which simplifies the design control problem significantly.

Beside the feedback loop, the important fact of implicit derivation of a feedforward control strategy by the inverse system representation should be pointed out. By the inverse representation a relation between a reference output function and an idealized input function over time t which needs to be applied to force the system to follow the reference trajectory is given. This element can be found in the flat system representation very clearly and in fact is hidden in the input output linearization in the same way.

It can be also applied for a linear system. Let us assume to have a proportional time delay system of order n concerning to the desired output (numerator of transfer function is 1). If you apply the input reference function not directly on the proportional time delay system, and instead of that you introduce a numerator term which will cancel out your denominator, you will have at the end a transfer function identical to one. That means your output function will follow your reference function ideally, as far as you not violate any constraints. In this case it would mean, you must apply on the system at least a reference function for the output, which is steady concerning to the n -th derivative. Otherwise you would violate the assumptions for linearity. For a crane modelled as a simple crane linearized pendulum system you have concerning to the load position a transfer function of 4th order. That means if you want to track a load position you need continuous reference functions up to the 3rd order, and for the 4th order at minimum a steady function. This is in fact the reason for the long follow-up movement of anti sway systems. Now we have the ability, if we minimize our reference functions for the fourth derivative concerning to the follow up movement, of course, not violating the given kinematic constraints of the system we can reduce the effect significantly.

In the following we will now introduce roughly the decentralized control approach by input output linearization for the Liebherr boom crane considering the nonlinear kinematics in the drives.

4. SIMPLIFIED MODEL FOR THE LUFFING MOVEMENT

The load sway in radial direction with the radial rope angle φ_r is described by the simple pendulum equation

$$\ddot{\varphi}_{Sr} + \frac{g}{l_S} \sin(\varphi_{Sr}) = -\frac{1}{l_S} \ddot{r}_A + \frac{1}{l_S} (r_A + l_S \varphi_{Sr}) \dot{\varphi}_D^2. \quad (1)$$

As shown in Figure 5, φ_{Sr} is the radial rope angle, $\ddot{\varphi}_{Sr}$ the radial angular acceleration, $\dot{\varphi}_D$ the cranes rotational angular velocity, l_S the rope length, r_A the distance from the vertical axis to the end of the boom, \ddot{r}_A the radial acceleration of the end of the boom and g the gravitational constant. F_Z presents the centrifugal force, caused by a slewing motion of the boom crane.

The second part of the nonlinear model is obtained by taking the actuators kinematics and dynamics into account. This actuator is a hydraulic cylinder attached between tower and boom. Its dynamics can be approximated with a first order system.

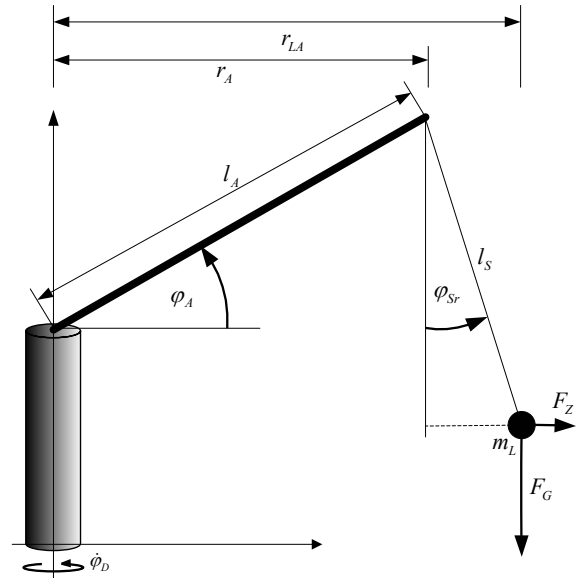

Figure 5. Schematics of the boom crane in radial direction

Considering the actuators dynamics, the differential equation for the motion of the cylinder is obtained as follows

$$\ddot{z}_{zyl} = -\frac{1}{T_W} \dot{z}_{zyl} + \frac{K_{VW}}{T_W A_{zyl}} u_l, \quad (2)$$

where \ddot{z}_{zyl} and \dot{z}_{zyl} are the cylinder acceleration and velocity respectively, T_W the time constant, A_{zyl} the cross-sectional area of the cylinder, u_l the input voltage of the servo valve and K_{VW} the proportional constant of flow rate to u_l . In order to combine (1) and (2) they have to be in the same coordinates. Therefore a transformation of (2) from cylinder coordinates (z_{zyl}) to outreach coordinates (r_A) with the kinematical equation

$$r_A(z_{zyl}) = l_A \cos \left(\alpha_{A0} - \arccos \left(\frac{d_a^2 + d_b^2 - z_{zyl}^2}{2d_a d_b} \right) \right), \quad (3)$$

and its derivatives

$$\begin{aligned} \dot{r}_A &= -l_A \sin(\varphi_A) K_{Wz1}(\varphi_A) \dot{z}_{zyl} \\ \ddot{r}_A &= -l_A \sin(\varphi_A) K_{Wz1}(\varphi_A) \ddot{z}_{zyl} - K_{Wz3}(\varphi_A) \dot{z}_{zyl}^2 \end{aligned} \quad (4)$$

is necessary. Where the dependency from the geometric constants d_a , d_b , α_1 , α_2 and the luffing angle φ_A is substituted by K_{Wz1} and K_{Wz3} . The geometric constants, the luffing angle and l_A , which is the length of the boom, are shown in Figure 6.

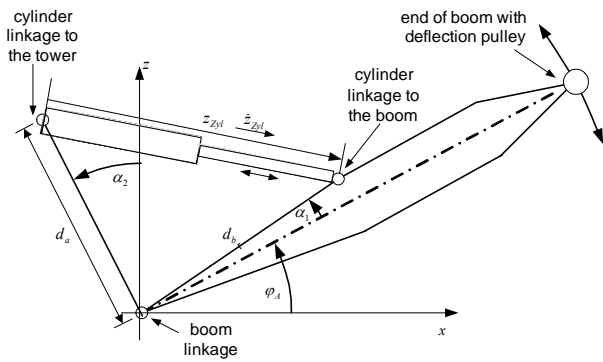

Figure 6. Cylinder kinematics

As result of the transformation, (2) can be displayed in outreach coordinates:

$$\ddot{r}_A = -\frac{K_{Wz3}}{l_A^2 \sin^2(\varphi_A) K_{Wz1}^2} \dot{r}_A^2 - \frac{1}{b} \dot{r}_A - \frac{K_{VW} l_A \sin(\varphi_A) K_{Wz1}}{T_W A_{zyl} m} u_l. \quad (5)$$

In order to obtain a nonlinear model in the input affine form

$$\begin{aligned} \dot{\underline{x}} &= \underline{f}(\underline{x}) + \underline{g}(\underline{x})u_l + p(\underline{x})w \\ y &= h(\underline{x}) \end{aligned} \quad (6)$$

equations (1) and (5) are used. The second input w represents the disturbance which is the square of the crane's rotational angular speed $\dot{\varphi}_D^2$. With the states defined as $\underline{x} = [r_A \ \dot{r}_A \ \varphi_{St} \ \dot{\varphi}_{St}]^T$ and the output $y = r_{LA}$ follow the vector fields

$$\begin{aligned} \underline{f}(\underline{x}) &= \begin{bmatrix} x_2 \\ -ax_2^2 - bx_2 \\ x_4 \\ -\frac{g}{l_S} \sin(x_3) + \frac{\cos(x_3)}{l_S} (ax_2^2 + bx_2) \end{bmatrix} \\ \underline{g}(\underline{x}) &= \begin{bmatrix} 0 \\ -m \\ 0 \\ \frac{\cos(x_3)m}{l_S} \end{bmatrix} \\ \underline{p}(\underline{x}) &= \begin{bmatrix} 0 & 0 & 0 & \frac{\cos(x_3)(x_1 + l_S \sin(x_3))}{l_S} \end{bmatrix}^T \end{aligned} \quad (7)$$

and the function

$$h(\underline{x}) = x_1 + l_S \sin(x_3). \quad (8)$$

5. INPUT-OUTPUT LINEARIZATION AS CONTROL APPROACH FOR THE LUFFING MOVEMENT

The relative degree concerning the systems output is defined by the following conditions

$$\begin{aligned} L_{\underline{g}} L_{\underline{f}}^i h(\underline{x}) &= 0 \quad \forall i = 0, \dots, r-2 \\ L_{\underline{g}} L_{\underline{f}}^{r-1} h(\underline{x}) &\neq 0 \quad \forall \underline{x} \in R^n. \end{aligned} \quad (9)$$

The operator $L_{\underline{f}}$ represents the Lie derivative along the vector field \underline{f} and $L_{\underline{g}}$ along the vector field \underline{g} respectively. With the output

$$y^* = h^*(\underline{x}) = x_1 + l_S x_3 \quad (10)$$

a relative degree of $r = 4$ is obtained.

The relative degree with respect to the disturbance is defined as follows:

$$L_{\underline{p}} L_{\underline{f}}^i h(\underline{x}) = 0 \quad \forall i = 0, \dots, r_d - 2. \quad (11)$$

Here it is not important whether r_d is well defined or not. Therefore the second condition can be omitted. Applying (11) to the reduced nonlinear system (6) and (7) with the linearizing output y^* the relative degree is $r_d = 2$.

Any disturbance satisfying the following condition can be decoupled from the output.

$$L_{\underline{p}} L_{\underline{f}}^i h(\underline{x}) = 0 \quad \forall i = 0, \dots, r-1. \quad (12)$$

This means the disturbance's relative degree r_d has to be larger than the system's relative degree. When there is the possibility to measure the disturbance a slightly weaker condition has to be fulfilled. In this case it is necessary that the relative degrees r_d and r are equal. Due to these two conditions, it is in a classical way impossible to achieve an output behaviour of our system which is not influenced by the disturbance.

To obtain a disturbance's relative degree which is equal to the system's relative degree a model expansion is required. With the introduction of $r - r_d = 2$ new states which are defined as follows

$$\begin{aligned} \sqrt{w} &= x_5 = \dot{\varphi}_D \\ \frac{d}{dt}(\sqrt{w}) &= x_6 = \ddot{\varphi}_D \\ \frac{d^2}{dt^2}(\sqrt{w}) &= \dot{x}_6 = \ddot{\varphi}_D = w^* \end{aligned} \quad (13)$$

the new model is described by the following differential equations

$$\begin{aligned} \dot{\underline{x}} &= \underbrace{\begin{bmatrix} f(\underline{x}) + p(\underline{x})x_5^2 \\ x_6 \\ 0 \end{bmatrix}}_{\underline{f}^*(\underline{x})} + \underbrace{\begin{bmatrix} g(\underline{x}) \\ 0 \\ 0 \end{bmatrix}}_{\underline{g}^*(\underline{x})} u_l + \underbrace{\begin{bmatrix} 0 \\ 0 \\ 1 \end{bmatrix}}_{\underline{p}^*(\underline{x})} w^* \\ y &= h^*(\underline{x}). \end{aligned} \quad (14)$$

This Expansion remains the system's relative degree unaffected whereas the disturbance's relative degree is enlarged by 2. The additional dynamics can be interpreted as a disturbance model.

Hence the expanded model has a system and disturbance relative degree of 4 and the disturbance w^* is measurable, it can be input/output linearized and disturbance decoupled with the following control input

compensating movements during acceleration and deceleration reduce the load sway in radial direction.

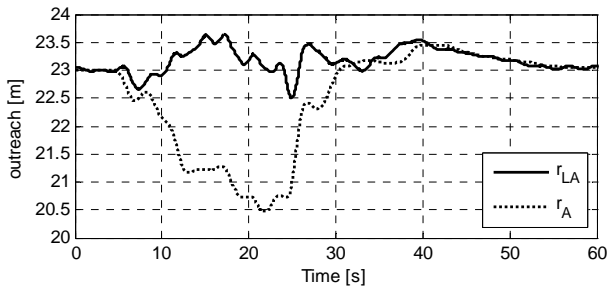

Figure 9. Outreach of payload and boom during rotation

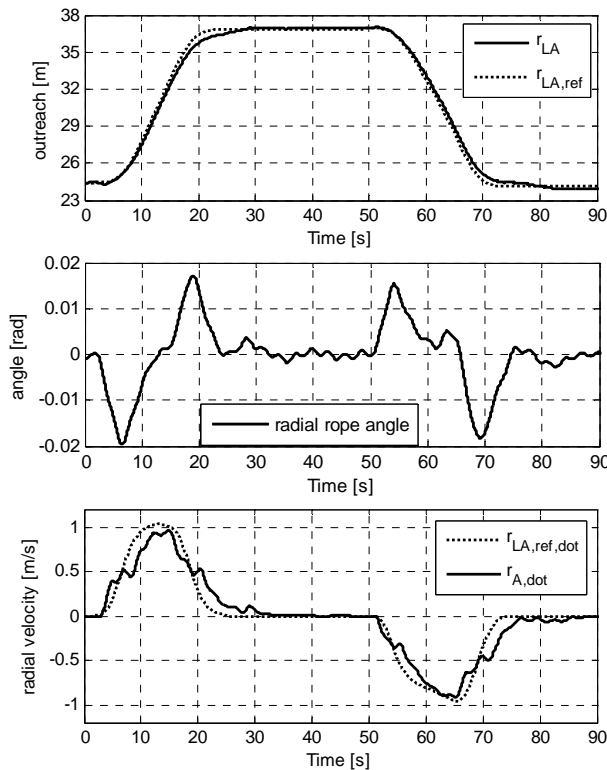

Figure 10. Luffing movement

The next manoeuvre is a combined manoeuvre containing a slewing and luffing motion of the crane. This is the most important case at transshipment processes in harbours mainly because of obstacles in the workspace of the crane. Figure 11 shows a polar plot where the payloads radius gets increased by 10 m while rotating the crane.

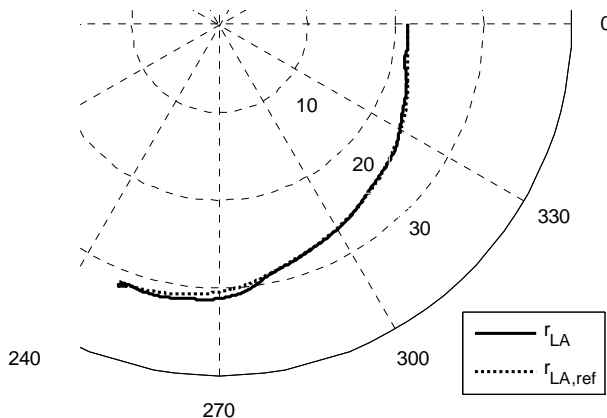

Figure 11. Payloads position during the combined motion

Figure 12 displays the same results but over time in order to illustrate, that the radial position of the load follows the reference.

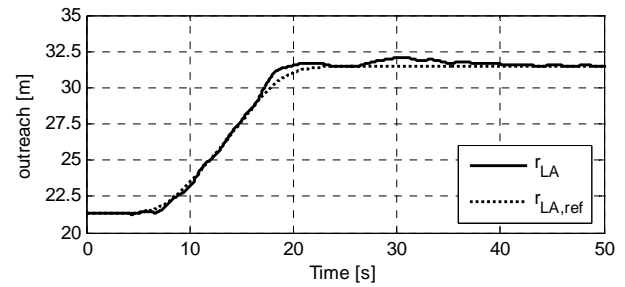

Figure 12. Outreach of payload during combined maneuver

Comparing these results with that of the luffing motion it can be seen that the achieved tracking performance remains equal. Because of the disturbance decoupling it is possible to achieve a very low residual sway and good target position accuracy for luffing and slewing movements as well as for combined manoeuvres.

7. CONCLUSION

In the paper different approaches for crane control were discussed. At the example of the Liebherr harbour mobile crane the input/output linearization technique was presented in detail as an anti-sway and tracking control concept for boom cranes. In order to support the crane operator during the transshipment process, the joystick commands have to be manipulated by the controller such that the resulting transfer of the load is characterized by no overshoot, small residual load sway, and exact trajectory tracking behaviour. The control concept consists of feedback and feedforward controller, disturbance observers, and a trajectory generation module. The system is as Liebherr Cycprotonic on the market and with more than 100 installations worldwide a successful product.

REFERENCES

- [1] Beeston, J.W.: Closed-loop time optimal control of a suspended load – a design study, in: *Proceedings of the 4th IFAC World Congress*, 1969, Warsaw, Poland, pp. 85-99.
- [2] Auernig, J.W. and Troger, H.: Time optimal control of overhead cranes with hoisting of the load, *Automatica*, Vol. 23, No. 4, pp. 437-447, 1987.
- [3] Sakawa, Y. and Shindo, Y.: Optimal control of container cranes, *Automatica*, Vol. 18, No. 3, pp. 257-266, 1982.
- [4] Carbon, L.: Automation of grab cranes, *Siemens Review*, Vol. 53, No. 2, pp. 80-85, 1976.
- [5] Tanaka, S. and Kouno, S.: Automatic measurement and control of the attitude of crane lifters: Lifter-attitude measurement and control, *Control Engineering Practice*, Vol. 6, No. 9, pp. 1099-1107, 1998.
- [6] Sawodny, O., Aschemann, H. and Lahres, S.: An automated gantry crane as a large workspace robot, *Control Engineering Practice*, Vol. 10, No. 12, pp. 1323-1338, 2002.

- [7] CePlus, <http://www.ceplus.biz/community/cesar-maxx-en.php>
- [8] Sawodny, O. and Aschemann, H.: Bahnregelung für den transfaster, Hebezeuge Fördermittel, Vol. 42, pp. 200-201, 2002.
- [9] Sawodny, O., Hildebrandt, A. and Schneider, K.: Harbour mobile cranes for automated boom crane operation, *Port Technology International*, No. 20, pp. 99-101, 2003.
- [10] Salminen, R.T., Marttinen, A. and Virkkunen, J.: Adaptive pole placement control of a pilot crane, in: *Proceedings of the 11th IFAC World Congress*, 13-17.08.1990, Tallinn, Estonia, pp. 313-318.
- [11] Sawodny, O., Aschemann, H., Kümpel, J., Tarin, C. and Schneider, K.: Anti-sway control for boom cranes, in: *Proceedings of the American Control Conference (ACC)*, 08-10.05.2002, Anchorage, USA, pp. 244-249.
- [12] Isidori, A.: *Nonlinear Control Systems*, Springer, New York, 1995.
- [13] Arnold, E., Neupert, J., Sawodny, O. and Schneider, K.: Trajectory tracking for boom cranes based on nonlinear control and optimal trajectory generation, in: *Proceedings of the IEEE International Conference on Control Applications*, 01-03.10.2007, Singapore, Singapore, pp. 1444-1449.
- [14] Fliess, M., Lévine, J., Martin, P. and Rouchon, P.: Flatness and defect of non-linear systems: Introductory theory and examples, *International Journal of Control*, Vol. 61, No. 6, pp. 1327-1361, 1995.

АКТУЕЛНИ ПРАВЦИ АУТОМАТИЗАЦИЈЕ ДИЗАЛИЦА – СМЕРНИЦЕ ЗА БУДУЋНОСТ

Оливер Заводни, Јерг Нојперт, Екар Арнолд

У индустрији су заступљени савремени ужетни системи за руковање теретом. Међутим, чак и у случају квалификованих оператера и повећаних носивости, још увек је дизаличар довољно конкурентан да спречи свеопшту употребу аутоматизованих система. У овом раду се разматра актуелно стање ствари у области аутоматизације дизалица. Као пример је представљен концепт аутоматизације обртне дизалице, настао у сарадњи са компанијом *LIEBHERR*. Разматрани су захтеви за сензорским и актуаторским системима. Сензорски систем за угао ужета нарочито представља критичну тачку. Изложени су и упоређени различити сензорски системи. Разматрани су захтеви за актуаторе у вези са потребним динамичким понашањем. Уведен је концепт управљања, а његова ефикасност је представљена резултатима мерења. Концепт управљања углавном користи две значајне методе из теорије управљања. После кратког увода у теорију равних система и предиктивног приступа моделу као алату за генерисање трајекторија које могу да се изведу, приказан је начин како се то примењује на аутоматски систем обртне дизалице. Смернице за будућност се изводе из дискусије о наредним унапређењима дизаличних система.