

**V. V. Krishna**  
PG Scholar  
Cochin University of Science and  
Technology  
Department of Mechanical Engineering  
India

**C.B. Suresh**  
Senior Research Engineer  
Fluid Control Research Institute  
Palakkad  
India

**M.R.R. Panicker**  
Associate Professor  
Cochin University of Science and  
Technology  
Faculty of Mechanical Engineering  
India

**Tide P.S.**  
Professor  
Cochin University of Science and  
Technology  
Faculty of Mechanical Engineering  
India

# Experimental Analysis of Multiport Averaging Device and Effect of Body Shape on Flow Coefficient

*This paper deals with the experimental results obtained using different shapes of multi-port averaging device at different gauge pressure. The cross-section of the multiport averaging device is essential factor which effects the meter performance. A closed loop air test facility (CLATF) is used for testing and calibration of the flowmeter, which is used to measure the air flow rate or velocity of flow. The circular probe is a commercial design while the diamond shape with slight modification is analyzed for providing better performance and appreciable result with less disturbance in the flow line. The prototype test of the flowmeter is done at a defined length of upstream straight pipe after an elbow bend, for a condition of well defined turbulent flow profile. The calibration is done at 2 and 5 gauge pressure while the flow rate varied from 0.0283 to 0.1121 m<sup>3</sup>/s. As a result, the diamond shaped probe with curved edges provided appreciable differential pressure and flow coefficient compared to circular probe keeping the same blockage to both the probe facing the flow.*

**Keywords:** Flow measurement, APT, flow coefficient, probe, differential pressure flowmeter, gauge pressure.

## 1. INTRODUCTION

Flow measurements in industries include measurement of flow rate of solids, liquids and gases. Measurement technology initialises the tool for optimizing production process, treatment plants and other dosing operations. In addition to that, the flow rate or velocity is one of the important measured variables. Proper determination of flow rate optimizes the industrial processes and other applications through proper control and regulation. Flowmeter is a device that measures the flow rate or quantity of the working fluid in open or closed system. There are many obstruction type flow meters which include orificemeter, nozzles, venturimeter, etc that are commonly used in closed conduit. Such devices disturb the flow which results in huge pressure loss in the pipe line. For keeping the pressure loss and other disturbances in the flow stream, we introduce multi-port averaging devices. Multi-port averaging device is a differential pressure flowmeter which determines the flow rate by measuring the change in pressure obtained due to the blockage of probe. These devices use Bernoulli's principle to measure the flow rate. The change in pressure is obtained by the upstream and downstream pressure of the probe. The properties considered during the selection of flowmeter are meter accuracy, linearity, flow rangeability, output signal characteristics, response time and uncertainty.

The main drawback in the flow measurement

technique is that small range of differential pressure or pressure change may result in calibration error. So to limit this disadvantage we need acquire considerable range of operation pressure change with less fluctuating signals. Measurement uncertainty is also caused due to incorrect installation of the flowmeter. Industrial practice uses different cross-sectional shape flowmeter according to the requirement.

## 2. MULTIPOINT AVERAGING DEVICE

A modified version of conventional pitot static tubes called multiport averaging device find wide applications in different industries which helps in overcoming the disadvantages of conventional version. Multiport averaging device is also known as Averaging Pitot Tube (APT) which scans the entire velocity profile across the closed conduit, producing a differential pressure as the secondary output. Continuously averaging of the velocity profile in judiciously positioned total pressure port connected chamber. At downstream or flow past the probe, creates a region of low pressure due to the vortex generation. Location of low pressure static port is located at 90° opposite of high pressure. Probe itself is considered as the primary device which creates a differential pressure output due to the effect of flow that has square root relationship with the flow rate.

Multiport averaging device has less sensitivity to velocity profile changes due to Reynolds numbers if installed properly with modified shape of probe. When there is large diameter sensing port, it can be used for dust laden gases. The tubes are normally used for high operating pressure, temperature and may be of large size. Main advantage of the device is that initial cost and installation cost is low, especially for large size pipe lines. Non-wear, non-clog design simplifies the

---

Received: June 2015, Accepted: August 2015  
Correspondence to: Prof. Tide P.S, Cochin University of  
Science and Technology, Faculty of Mechanical  
Engineering, Kerala, India,  
E-mail: tideps@gmail.com  
**doi:10.5937/fmet1701038J**

© Faculty of Mechanical Engineering, Belgrade. All rights reserved

FME Transactions (2017) 45, 32-27 32

preventive maintenance. The main problem occurs when the measurement takes place for low flow rate that involves low differential pressures. Combustion products may block the sensing ports and periodic cleaning must be needed to avoid error in flow measurement. It is widely used especially for large pipe line sections with advantages of simple design, easy installation and take down, low pressure loss and less costly.

APT is widely used in many applications while other air flow devices like orifices, flow nozzles, venturis are conventional flowmeters. The advantages of this device compared to other differential pressure flowmeters are simple construction, easy installation, good accuracy with long term stability, reduced pressure loss and low cost. It is now commonly used in power plants, petrochemical, iron and steel industry and other fields.

## 2.1 Design History

Seshadri et al.[1] analyzed the meter factor, the pressure loss, the flow fields around the probe of the annubar type APT flowmeter. D.Wecel et al. [2] has investigated the meter performance for different cross-sections. Dobrowolski et al. [3] compared the meter characteristics of the probe and made a mathematical model and analyzed streamline section. Comparison of fifteen different cross-sections, and which was then concluded by optimization of design to a two-profile cross-section was put forward by Kabacinski and Pospolita[4].

Li-jun Sun et al.[5] investigated the meter performance using APT with flow conditioning wing using a prototype test. It was found that better linearity, repeatability, and differential pressure was generated compared to the commercial design cross-sections.

Oh and Lee [6] designed a new APT flowmeter and its flow rate characteristics was evaluated. Two kinds of differential pressure measured flowmeter were used. One H parameter (HAP1) calculated based on the difference between upstream at flowmeter and static pressure of the measured flow. The other H parameter (HAP2) which was used in a typical Annubar type flowmeter was calculated based on difference between upstream and downstream pressure at the developed flow meters. The results showed that curves based on HAP2 parameter indicated different gradients for varying controlled air temperature.

Vinod et al.[7] calibrated APT by simulation. It is used to measure the thermally induced air flow through the sodium to air heat exchanger used to remove the decay heat generated in the core of the fast breeder reactor after its shutdown. The experimental velocity ranged from 1.417 to 2.25 m/s while the air temperature and relative humidity was 24.5 and 59.5 respectively. The polynomial fitted with numerically derived data points was found out as given below Reynolds number, Re ranging from  $4 \times 10^4$  to  $5 \times 10^5$ .

$$C_p = 0.5595 - 0.4549e^{-\left(\frac{Re}{56133}\right)} \quad (1)$$

A probe shape with diameter of 10.2mm and height 152.4mm is considered for the experiment. The diameter of the test section is 6 inches.

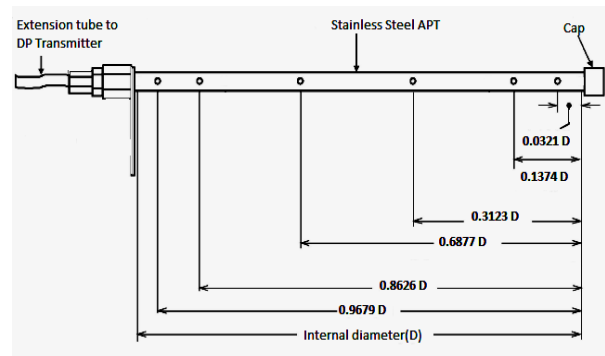


Figure 1. Multi-port averaging device showing relative position of openings for measuring upstream pressure

The probe mounting holes were grooved so as to facilitate positioning with 6 impulse hole in the direction of incoming flow and static hole in constriction area. Six holes are grooved at a distance of length 0.0321D, 0.1374D, 0.3123D, 0.6877D, 0.8626D and 0.9679D from one side of the pipe wall, (where D is the internal diameter of test pipe) based on Chebyshev method [9]. Here the static pressure is measured at the rear side of the flowmeter with single port while that single static hole is at the centre of the tube (i.e., 0.5 D). APT causes the lowest permanent pressure loss in the family of differential flowmeters.

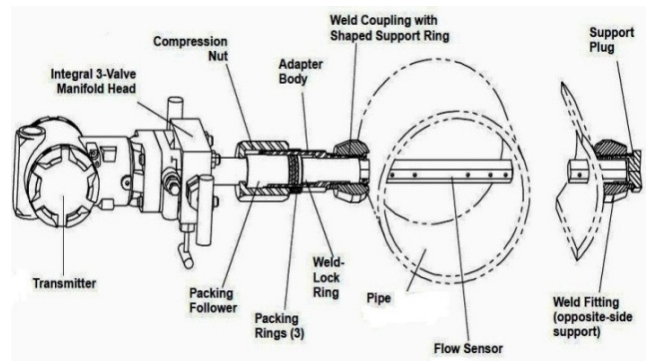


Figure 2. Simplified scheme of multi-port averaging device

If  $\Delta p$  is considered as the difference in pressure at the test location, from Bernoulli equation for incompressible fluids the volumetric flow rate is related to the flow coefficient, K by the equation (2):

$$Q_v = K \varepsilon \frac{\pi}{4} D^2 \sqrt{\frac{2\Delta p}{\rho}} \quad (2)$$

In the formula, K is dimensionless factor,  $\rho$  is the density of the fluid,  $\text{kg/m}^3$ , D is the internal diameter of pipe, m,  $\Delta p$  is the differential pressure generated measured using differential transducer, Pa and  $\varepsilon$  is the expansion coefficient which are usually considered as unity for liquids (incompressible fluids). This equation can be written in terms of averaging flow velocity,  $\tilde{v}$  as follows:

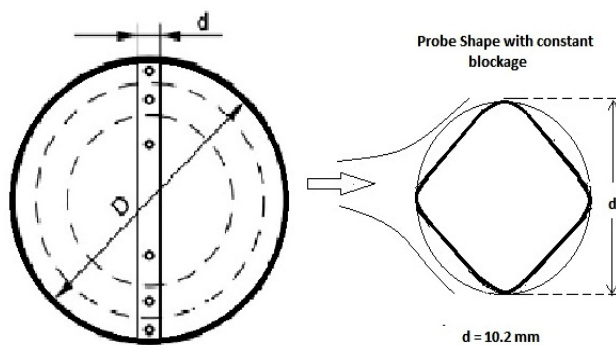
$$\tilde{v} = K \sqrt{\frac{2\Delta p}{\rho_f}} \quad (3)$$

The new multi-port averaging probe sensor is designed to meet the following points as mentioned below:

- (1) The differential pressure measured must be larger than existing productions with appreciable flow coefficient at same applied flow conditions.
- (2) To make reduced fluctuation or better linearity in the K-Re characteristics curve than existing probe shapes.
- (3) To follow the same square root relation for different gauge pressure in case of differential pressure-volumetric flow rate curve.

It was observed that distortion in velocity profile due to the disturbance in upstream does not affect significantly the flow coefficient if it is not substantial [7]. So the disturbance affects the downstream low pressure side of the flowmeter.

The probe coefficient depends largely on the shape and size of the APT due to the phenomenon of vortices or wake formation behind the flowmeter.



**Figure 3. Probe Shape with constant blockage considered for experimental analysis**

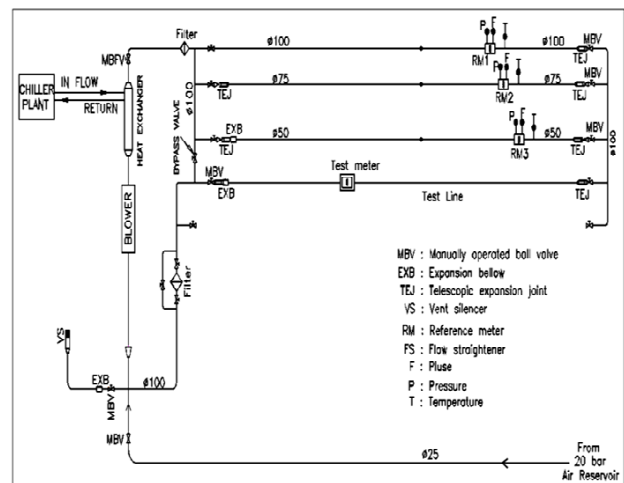
Two sides of the probe are having pressure detecting ports which are symmetrically arranged relative to the centre of the pipe according to the Chebyshev method. The multiport averaging device is a special type of differential flowmeter of which it causes lowest permanent pressure loss in the family of this flowmeter. The probe generates a differential pressure,  $\Delta p$  which has two components, the average total pressure,  $P_t$  and reference or static pressure,  $P_s$ . The equations relating flow rate to the pressure signal are:

$$\Delta p = P_t - P_s \quad (6)$$

The present work is concentrated on the study of the effect of body shape on flow coefficient with respect to the Reynolds number. The effect of differential pressure with varying flow rate for different gauge pressure is also analyzed. Actually, any fluctuation in probe coefficient causes inaccurate calibration results which include error in calculation of differential pressure and other parameters depending on it. One solution is by giving flow conditioning wings to the probe which provides fixed separation point for a wide range of Reynolds number. Other way is to provide a sharp edge probe structure. But both of these result in small value flow coefficient or disturbed flow at downstream of the flowmeter. At present, a modified diamond shaped probe is used by providing a corner radius of 1mm to the sharp edges. Fillet to the edges conditions the flow which reduces the length of the vortices formed at the downstream of the flowmeter.

### 3. EXPERIMENTAL SETUP

Experiment on multiport averaging device is conducted in Closed Loop Air Testing Facility (CLATF) lab at Fluid Control Research Institute (FCRI). The layout of the CLATF is given below in figure 4 [7].



**Figure 4. Layout of CLATF Lab[7]**

The working medium is air. The air from 20 bar reservoir is passed to the blower which passes through a heat exchanger, then reaches the reference line. Here, the flow is controlled by a Manually Operated Butterfly Valve (MBV). Thus, the air flow is controlled accordingly. The turbine meter is used as the reference flowmeter. Pressure, temperature and humidity sensors are incorporated into the test line. After passing through the test flowmeter, i.e., multi-port averaging device, air passes back to the blower through a filter. Thus the air is re-circulated continuously until the completion of the experiment at given gauge pressure. Finally, the air is vent out through the vent silencer only if there is a requirement of aligning the flowmeter in different manner. The instruments used for carrying out the experiments were universal counter, multi-functional pressure indicator, digital temperature indicator with RTD, turbine meter as reference meter, encapsulated blower, electronic humidity transmitter and APT.

Experiment is done using the air as working fluid. The experiment is conducted for two different shapes of probe with constant blockage. One is commercial design having circular shape with probe diameter,  $d=10.2\text{mm}$ , while other is modified diamond shape ( $10.2 \times 10.2\text{ mm}$ ) with  $10.2\text{mm}$  diagonal surface facing the flow, avoiding sharp edges by giving  $1\text{mm}$  corner radius while the fluid flow rate is varied from  $0.0283$  to  $0.1121\text{ m}^3/\text{s}$  ( $100 \sim 400\text{ m}^3/\text{h}$ ). Moreover, for calculations used,  $D=152.4\text{mm}$  (pipeline internal diameter),  $n=6$  (number of impulse holes in the upstream section of probe),  $L1=18D$  (length of upstream distance after an elbow bend of pipe from reference line) and  $L2=7$  (length of downstream after the test meter).

Distortion in the velocity profile and reverse flow is avoided by providing necessary upstream and downstream distance from the test flow meter. The distance from the flow disturbing element and plane in which the sensor is located affects the uncertainty of measurements of the flow averaging Pitot tubes [10].

Only two elbow bend after the reference flow meter is used in the experiments which are in the same plane.

**Table 1. Calibration at 2bar gauge pressure**

Shapes considered	From experiments			
	Volumetric flow rate, m <sup>3</sup> /s	Re	$\Delta p$ (Pa)	K
Circular	0.0287	45222.96	7.38	0.752
	0.0425	66792.92	18.37	0.705
	0.0565	88569.23	31.27	0.717
	0.0716	108824.30	53.77	0.682
	0.0846	131422.37	77.25	0.691
	0.0978	152651.57	110.81	0.665
Diamond	0.1032	159387.80	130.91	0.672
	0.0278	44367.12	12.04	0.577
	0.0416	66254.36	24.37	0.606
	0.0555	88698.10	40.50	0.630
	0.0687	109075.69	63.45	0.621
	0.0838	132378.30	88.87	0.639
	0.0955	150064.60	114.75	0.641
	0.1038	160870.87	145.12	0.621

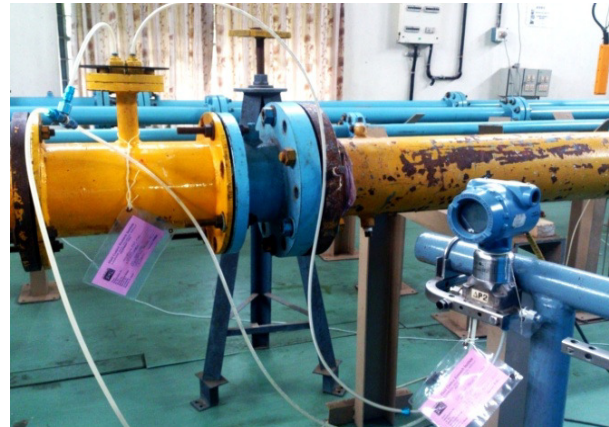
**Table 2. Calibration at 5bar gauge pressure**

Shapes considered	From experiments			
	Volumetric flow rate, m <sup>3</sup> /s	Re	$\Delta p$ (Pa)	K
Circular	0.0283	88770.50	15.15	0.737
	0.0434	136405.84	43.50	0.665
	0.0567	174236.09	66.37	0.699
	0.0692	212523.94	95.21	0.715
	0.0835	258601.10	145.61	0.696
	0.1014	316751.52	197.40	0.726
	0.1121	353098.12	273.82	0.683
Diamond	0.0279	85984.18	22.36	0.593
	0.0420	128940.32	41.34	0.657
	0.0562	172210.13	76.37	0.647
	0.0684	209270.34	109.93	0.656
	0.0837	253733.86	171.63	0.640
	0.0973	296561.33	222.83	0.652
	0.1115	335830.15	318.83	0.631

The expanded uncertainty of the turbine flowmeter (reference meter) is 0.3%. The expended uncertainty of the whole closed loop test facility (CLATF) is 0.35%. For the entire test conducted, there was the pressure and temperature variation. Table 1. and Table 2. shows experimental values obtained during calibration. The calibrated air flow for 2 bar gauge pressure had a temperature of 296.45 K, density of 3.575 kg/m<sup>3</sup> and the dynamic viscosity of 18.421x10<sup>-6</sup>. The pulse rate produced by reference meter varied from 26795~99934 per minute and had a compressibility of 0.99908.

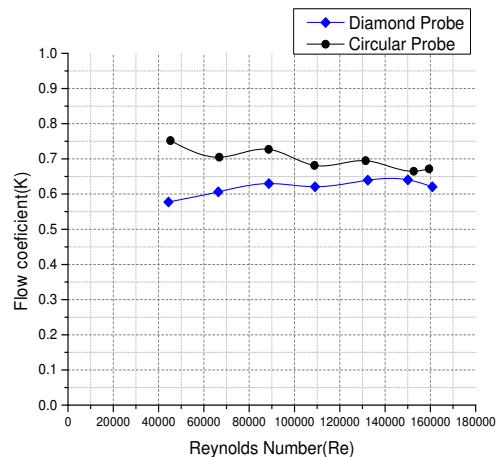
Similarly calibrated air flow for 5 bar gauge pressure had a temperature of 296.12 K, density of 6.933 kg/m<sup>3</sup> and the dynamic viscosity of 18.435x10<sup>-6</sup> Pa.s. The pulse rate produced by reference meter as 26888~107846 and compressibility of 0.99801. The

density varied according to the gauge pressure applied in the closed loop.

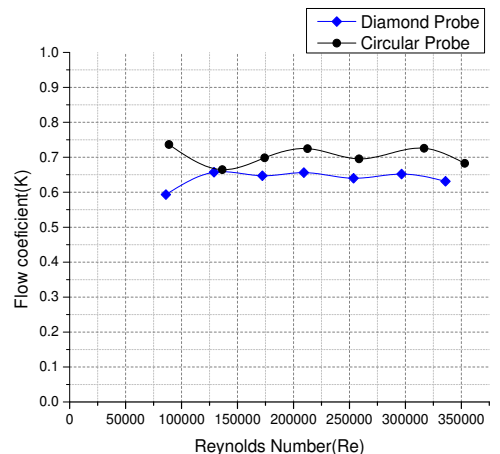


**Figure 5. Flowmeter connected with differential pressure transmitter in CLATF lab**

Characteristic curves were formed by both the probe shapes where diamond shaped probe was made less depend of flow coefficient curve with respect to Reynolds number while the circular probe characteristic curve  $K=f(\tilde{v})$  shows more fluctuation which is summarized in figures 6 and 7.



**Figure 6. Characteristics of the flow coefficient, K for circular and diamond probe inserted in pipe line of internal diameter, D=152.4 mm at 2 bar gauge pressure**

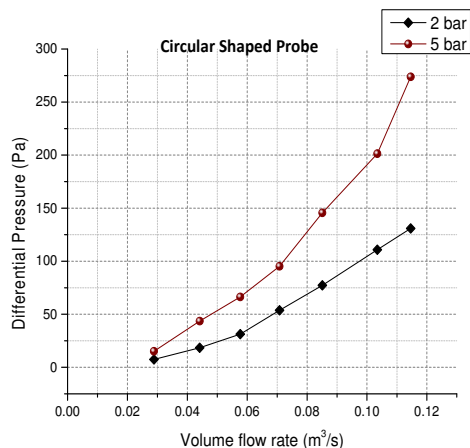


**Figure 7. Characteristics of the flow coefficient, K for Circular and diamond probe inserted in pipe line of internal diameter, D=152.4 mm at 5 bar gauge pressure**



The fluctuations arise from the instabilities that grow until the nonlinear interactions causes them to break down into finer and finer whirls that eventually are dissipated by the action of viscosity.

The graph plotted based on differential pressure and velocity, shows a square root relation during the entire test at differential gauge pressure. The range of DP signal varied from 7.388 to 118.913 Pa during the entire test and velocity varies from 1.543 to 5.491 m/s near APT for 5 bar gauge pressure.



**Figure 8. Graphical representation of differential pressure curves formed at varying flow rate by inserting circular probe in the flow stream at different gauge pressure**

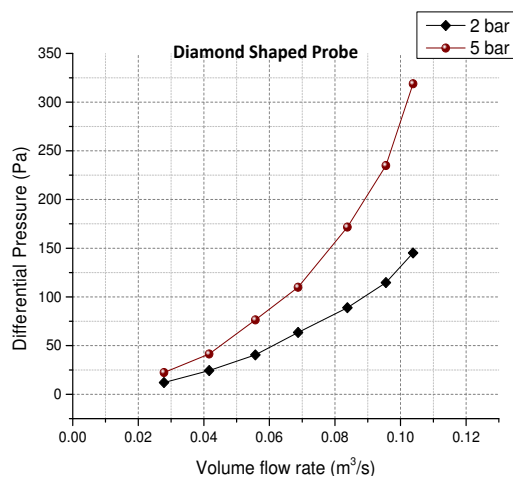
The physical features of the multi-port device have large effect on the performance of the primary, with the feature being the actual shape of the sensor. The result showed that round or cylindrical probe presents the limitation of variable separation at different flow rates and reduced differential pressure comparatively. At 2 bar gauge pressure, the differential pressure obtained for both probe shapes used for prototype test has it comparatively lower than that at 5 bar gauge pressure.

#### 4. CONCLUSION

The knowledge of the right value of the probe coefficient is important for the accurate flow measurement. This coefficient is calculated experimentally with a mean value of 0.705 and 0.639 for circular and diamond shape at 5 bar gauge pressure respectively. It indicates slight variation in case of 2 bar gauge pressure at the same range of flow rate, i.e., 0.698 and 0.619 for circular and diamond shape respectively. By this the optimization range of flow coefficient with respect to Reynolds number for using both the shapes were found out i.e., at 2 bar gauge pressure, for modified diamond shaped probe there exists  $\pm 1.3\%$  variation in K at  $6.6354 \times 10^4 < Re < 1.6087 \times 10^5$  while circular probe with  $\pm 1.97\%$  variation in K at  $6.6793 \times 10^4 < Re < 1.5939 \times 10^5$ .

At 5 bar gauge pressure, for diamond probe there exists  $\pm 1.1014\%$  variation in the flow coefficient at  $1.2894 \times 10^5 < Re < 3.3583 \times 10^5$  while circular probe with  $\pm 2.235\%$  variation in K at  $1.3641 \times 10^5 < Re < 3.5310 \times 10^5$ . By providing 1mm corner radius the probe coefficient has improved, where the lateral width kept constant. Results showed that at both 2 bar and 5 bar gauge pressure for both shapes considered, the circular

shape made large fluctuation in the flow coefficient with respect to Reynolds number ( $8.8771 \times 10^4$  to  $3.5310 \times 10^5$ ), while a flat characteristic is shown for modified diamond shape i.e.,  $8.5984 \times 10^4$  to  $3.5383 \times 10^5$ . Thus the smooth flat characteristics provide better result for flow measurement. Modified shape implies fixed separation with minimised variations and improved flow coefficient throughout the flow range. Experimental work shows that different gauge pressure differential pressure has more effect but the square root relation is satisfied for both cases. As the gauge pressure increases the change in pressure indicated increment in value with respect to the flow rate due to large vortex generation at downstream of the test flowmeter. Such increase in differential pressure for low flow rates gives more accurate calibration results with minimized error in flow measurement. It elaborates the dependence and importance of flow coefficient at different gauge pressure.



**Figure 9. Graphical representation of differential pressure curves formed at varying flow rate by inserting diamond shaped probe in the flow stream at different gauge pressure**

#### ACKNOWLEDGMENT

This research was performed under the Fluid Control Research Institute (Govt. of India, Palakkad) supported by the Cochin University of Science and Technology. Expressing sincere gratitude towards Shri. C.B. Suresh, Dr. Tide P.S and Dr. M.R. Radhakrishna Panicker for their kind assistance and guidance.

#### REFERENCES

- [1] V. Seshadri, et al. "Analysis of the effect of body shape on annubar factor using CFD," Measurement, Vol.35, pp.25-32, 2004.
- [2] D. Wecel, et al., "Experimental and numerical investigations of the averaging Pitot tube and analysis of installation effects on the flow coefficient," Journal of Flow Measurement and Instrumentation, Vol. 19, no 6, pp. 301-306, 2008.
- [3] B. Dobrowolski, M. Kabacinski, J. Pospolita, "A mathematical model of the self-averaging Pitot tubes," Flow Measurement and Instrumentation, Vol. 16, pp. 251-265, 2005.
- [4] M. Kabacinski, P. Pospolita, "Experimental research into a new design of flow-averaging tube" Flow

measurement and Instrumentation, Vol.22, pp. 421-427, 2011.

- [5] L.J. Sun, et al., "Numerical Simulation and Experiment on Averaging Pitot tube with Flow Conditioning Wing," 15<sup>th</sup> Flow Measurement Conference (FLOMEKO), October 13-15, 2010.
- [6] Oh and Lee, A comparative study of flow rate characteristics of an averaging pitot tube type flow meter according to H parameters based on two kinds of differential pressure measured at the flow meter with varying air temperature, Journal of Mechanical Science and Technology 25, Vol.8, pp.1961-1967, 2011.
- [7] Averaging Pitot tube- Flowmeter Report, Fluid Control Research Institute, FCRI, SI No: FCRI/AFL/HP/A06, pp.1-7, 2012.
- [8] V. Vinod, et al., "Calibration of an averaging pitot tube by numerical simulations", Flow Measurement and Instrumentation, Vol.24, pp.26-28, 2012.
- [9] Measurement of fluid flow in closed conduits using multiport averaging pitot primary elements, ASME MFC-12M-2006.
- [10] S. Pochwala, et al., "Influence of typical flow disturbing elements on the flow rate in selected APT", Vol.16, pp.219-228, 2012.

---

**ЕКСПЕРИМЕНТАЛНА АНАЛИЗА  
ВИШЕПОРТНОГ УРЕЂАЈА ЗА**

**ОСРЕДЊАВАЊЕ И УТИЦАЈ ОБЛИКА ТЕЛА  
НА КОЕФИЦИЈЕНТ ПРОТОКА**

**В. Кришна, Ц. Суреш, М. Паникер, П. Тајд**

Рад се бави експерименталним резултатима добијеним коришћењем различитих облика вишепортног уређаја за осредњавање при различитим притисцима мерача. Попречни пресек овог уређаја значајно утиче на перформансе мерача. Постројење за испитивање типа closed loop (CLATF) коришћено је за испитивање и калибрисање протокомерача, који се користи за мерење нивоа протока ваздуха као и брзине протока. Секторска сонда је пројектована у комерцијалне сврхе, док се незнатно модификована сонда у облику дијаманта анализира у циљу постизања бољих перформанси и резултата са мање поремећаја у линији протока. Испитивање прототипа протокомерача извршено је при одређеној дужини праве цеви узводно непосредно после коленасте кривине код услова дефинисаног профила турбулентног струјања. Калибрисање манометара је обављено на притисак од 2 до 5, док је ниво протока варирао од 0,0283 до 0,1121 м<sup>3</sup>/с. Сонда у облику дијаманта са закривљеним ивицама показала је значајан диференцијални притисак и коефицијент протока у поређењу са секторском сондом, при чему је остало исто запречење код сонде у директном додиру са током ваздуха.