

V. F. C. Sousa

Researcher
ISEP – School of Engineering, Polytechnic
of Porto, Portugal

F. J. G. Silva

Associate Professor w/ Habilitation
ISEP – School of Engineering, Polytechnic
of Porto, Portugal

L. P. Ferreira

Associate Professor
ISEP – School of Engineering, Polytechnic
of Porto, Portugal

R. D. S. G. Campilho

Auxiliar Professor
ISEP – School of Engineering, Polytechnic
of Porto, Portugal

T. Pereira

Associate Professor
ISEP – School of Engineering, Polytechnic
of Porto, Portugal

E. Braga

Researcher
ISEP – School of Engineering, Polytechnic
of Porto, Portugal

Improving the Design of Nozzles Used in Zamak High-Pressure Die-Casting Process

The injection of light alloys is an activity that requires a high effort on the part of Engineering to maintain its competitiveness. Due to the temperatures used, the wear of the components connected to this manufacturing process is quite intense, requiring a constant updating effort. This work was developed with a view to solving problems related to the excessive wear of injection nozzles used in the die casting process, and corresponding electrical resistances, with a view to increase its lifetime and improve the competitiveness of the process in the injection of low-cost parts in zamak for the automotive industry. To study and solve the problems of premature wear of the injection nozzles, the action-research method was used, which, through several iterations, allowed to arrive at an improved design of the nozzle, as well as the corresponding electrical resistance, thus increasing the life span of these components, also improving safety around the process and generating knowledge that can be transferable to other similar situations.

Keywords: High-pressure die casting, Low-cost products; Competitiveness; Design improvement, Nozzles, Wear, Automotive industry.

1. INTRODUCTION

Since 2018, the automotive industry has experienced some stagnation in the production and sale of motor vehicles, a situation generated by the lack of definition in the propulsion systems, and which now tends to worsen with the pandemic situation experienced in 2020 and 2021. Competitiveness was already pointed out by many authors as one of the main pillars of the automotive industry [1-4], with constant improvements being developed and implemented, such as the reduction of vibrations in automotive systems, directly improving passenger comfort and ease of handling [5-6]. Furthermore, there is also a focus on the employment of different materials for automotive components, such as the use of composites for brake pads [7]. Due to the recent drop in sales, this competitiveness should still increase, in order that the different players in the market do not lose their market share to their competitors. In this respect, innovation is particularly important, and it is necessary to eliminate all waste and make all processes as efficient as possible [8-10], by designing new equipment for waste processing, enabling its reutilization and fast and safe disposal [11]

Bowden cables are low-cost components that are part of any car, transforming an action of one of the passengers of the car in the opening of a door, in the movement of a glass, or another mechanical command of any other component [12]. The low cost and added value of Bowden cables has triggered a series of studies

aimed at solving the most diverse problems related to their production [13-15]. Bowden cables are provided at their ends with small components injected in zamak, which are the responsible for transmitting the passenger's movement to the component that is intended to act, these cable types are quite useful for the transmission of movement, being widely applied, as mentioned in the automotive industry, with some recent studies applying these cable types to medical applications, namely the transmission of movement for limbs in exoskeletons [16-17]. Despite their small volume, these parts take on particular importance in the function performed by Bowden cables, since it is in these small components that passenger force is performed. The quality of these components is critical, having already been intensively studied [18-20]. The main constituent of a Bowden cable is a braided metallic cable, where plastic deformation is carried out at each end by hammering, dispersing the metallic wires and allowing the zamak to better embed these dispersed metallic wires, preventing the force exerted on the cable pull out these components injected at their ends. Moreover, customers usually imposed a minimum force limit that must be ensured by these cables [21].

Thus, high-pressure die casting is the process usually used to manufacture these Bowden cable ends in zamak alloy. In fact, high-pressure die-casting is an extremely expeditious process of producing metallic parts in their almost final form, dispensing, or requiring only slight machining operations, since the process allows for high precision and repeatability. This manufacturing process is widely used in the automotive industry for the manufacture of numerous parts with a complex shape, but which have positive draft angle from the mold, since the technique is essentially based on the filling under high pressure of a mold with the

Received: May 2021, Accepted: September 2021
Correspondence to: Francisco J.G. Silva, Associate
Professor, Polytechnic of Porto, ISEP-School of
Engineering, Porto, Portugal
E-mail: fgs@isep.ipp.pt
doi:10.5937/fme2104005S

© Faculty of Mechanical Engineering, Belgrade. All rights reserved

FME Transactions (2021) 49, 1005-1013 **1005**

final or near-final shape of the part. Water pumps, oil pumps, gearbox casings, steering boxes, are some of the many examples of parts that are manufactured in light alloys through high-pressure die-casting regarding the automotive industry. The process of injection of light alloys through high-pressure die-casting was extensively investigated in the last decades of the twentieth century and first decade of the current century [22-25], having lost some spark since then, although the molds and fluidity of the alloys, as well as the cooling process and correspondent microstructures continue to be highlighted in terms of research.

Even though light alloys present more moderate melting temperatures than ferrous alloys, the entire environment of the die casting process presents severe maintenance problems [22], as well as quality problems [26], as well as problems associated with material degradation over time [27], which require continuous efforts by the Engineering to reduce wear and increase quality [28]. In the process of high-pressure die casting, almost all components are critical in terms of maintenance, but molds are the component that is usually the most studied [22]. Though, molten material causes very careful maintenance needs from the oven to the injection nozzle, which leads the molten metal to the mold. However, the injection nozzles can also represent increased maintenance problems because they are permanently subject to high temperatures and are subject to high pressures inside them. In addition, the light alloys to be injected can also contain abrasive elements, such as the Silicon, which deteriorate the inner channel of the nozzles, promoting their rapid deterioration. The failure of the nozzles in service can cause serious safety problems, depending on how the injection system is protected, which represents an additional concern, given the principles of health and safety at work [29-30]. To increase competitiveness, which is particularly fierce in the automotive industry, companies are trying to develop components that can be more effective than the solutions traditionally presented in commercial terms. In fact, only an absolute mastery of the technologies this industry needs can guarantee high degrees of efficiency, with a correct balance between short cycle times and a level of quality and reproducibility at the level normally required by the automotive industry [31-34]. Moreover, companies increasingly tend to adhere to sustainability principles based on the triple bottom line, which has brought new ways of looking at the environment and resource management [35]. These principles, coupled with the need to ensure the necessary competitiveness, have led to priority being given to reducing the consumption of raw materials, reusing components and recycling, without forgetting a strong emphasis on energy saving, which must be present whenever new systems are designed [36]. Indeed, numerous studies can be found on filling molds through simulation [18-19,23-24], optimization of parameters [25,37] and molds lifespan [22,38], but there is a complete gap regarding the study and development of nozzles used in the high-pressure die-casting process.

This study was based on a problem posed by the industry, which faced serious problems with the

reliability of the injection nozzles in the manufacture of the ends of the Bowden cables used in motor vehicles. In fact, a change was made in the way the nozzles were heated, with a migration from the heating gas system, which caused several safety problems, to a completely electrical system, composed of a spiral resistance that embraces the nozzle, allowing it is at the appropriate temperature so that there is no solidification of the metal to be injected into the nozzle. While the gas heating process was perfectly stabilized, electrical resistance heating forced to rethink the entire nozzle architecture, including resistance. It should be noted that commercial solutions have serious limitations in terms of lifetime, and the cost of replacing the injection nozzles contributes significantly to the costs inherent in the process, a situation that is intended to be reversed, through an adequate study of the factors that affect the lifespan of the injection nozzles.

This work is structured in four sections. After this section in which a theoretical introduction to the automotive industry, Bowden cables and high-pressure die-casting is carried out, a second section follows, describing the methodology followed. The results are described in the third section. In the fourth section there is a brief discussion on the results obtained. In the fifth and last section, the main conclusions of this work are highlighted, which are the identified limitations and what knowledge can be transferable for the resolution of analogous situations.

2. METHODS

The research carried out through this work was based on an industrial need, which was taken as a starting point for the development of a solution that could be transferable to other similar situations, where it may be necessary to improve machine components subject to severe work conditions. Given that the resolution of the problem in question encompasses a series of specialties, such as materials, manufacturing technologies, thermal transfer phenomena, wear phenomena and redefinition of the geometry of a component (if we only consider the injection nozzle), it makes it essential to establish an adequate strategy to approach the problem and its resolution, with a view to simplifying the process and establishing possible standards for similar situations in the future. Thus, it was decided to opt for the Action-Research methodology, as it is a methodology based on the principle of "learning by doing". In fact, there are no previously conceived theories that would allow a purely scientific approach to the proposed problem. Thus, the Action-Research methodology will allow, through different iterations, to introduce improvements and learn from these improvements, producing knowledge and allowing the study to evolve in level, until a solution is reached that is within the parameters previously stipulated for the service life of the injection nozzles. Later, the acquired knowledge will be listed, so that this knowledge can be transferable to similar situations. Given that this work will require diverse iterations, it was decided to use the same methodology, but consisting only of five stages, as described in the work presented by Martins et al. [39]. The diagram corresponding to this methodology can be seen in Figure 1.

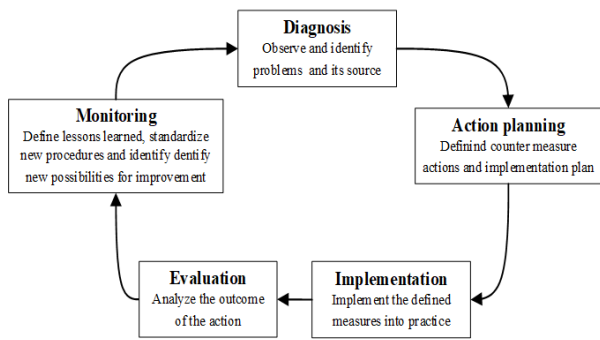

Figure 1. Different steps of the Action-Research cycle used in this work [31].

In the specific context of this work, the different phases previously described and depicted in Figure 1 can be translated into tangible actions, as described in Table 1.

Table 1. Specific content of each step of the Action-Research methodology regarding this work.

Step	Content
Diagnosis	Analysis of the inner channel of the nozzles. Hardness measurements.
Action Planning	Improvement of the inner channel design and study of the material used and corresponding treatments.
Implementation	Implementation of new design and selection of different material and heat-treatment.
Evaluation	Analysis of nozzle's behavior.
Monitoring/Outcomes	Lessons learned to transfer the knowledge acquired (Research outcomes) and, if the results are not good enough, new iteration should be performed considering the lessons learned.

The range of high-pressure die-casting operating parameters can be seen in Table 2.

Table 2. Range of operating parameters in high-pressure die casting.

Temperature (°C)	Pressure (bar)	Injection rate (Injections/h)
480 - 680	3 - 4	400 - 600

The diagnostic phase will still be carried out within this section of the methodology. The different iterations of planning actions, implementing changes, analysing results, drawing lessons learned and starting a new cycle will be described in the results section.

Starting with the diagnosis and considering that the service life of some nozzles did not reach an 8-hour shift, a plan for collecting and analysing the injection nozzles was implemented, as they were being removed from the sixty-two high-pressure die-casting equipment existing into the company. Externally, some of the nozzles showed evident signs of the appearance of a lateral hole through which liquid metal had escaped during the injection process (Figure 2). This evidence

led to several nozzles being cut by WEDM (Wire Electrical Discharge Machining), to analyse the inner channel in cross-section.

The analysis plan was immediately outlined: it would be necessary to analyse the initial and the final hardness in the cross-section, check the material's data-sheet in terms of heat treatments and level of hardness reached, verify which different treatments could have been applied to the nozzles after heat-treatment, and study how the flow was performed considering the initial geometry of the nozzles' internal channel.



Figure 2. External aspect of some nozzles removed from the high-pressure die-casting equipment after severe damage: (a) exhibiting a hole; (b) or even being broken

This analysis allowed us to immediately verify that the material used in the manufacture of the nozzles allowed high hardness after treatment, but that there was an abrupt drop after 550°C. It was also found that the injection nozzles were nitride at 580°C after the heat treatment, a situation that removed part of the hardness conferred by the initial heat treatment. An analysis of the manufacturing parameters used made it possible to verify that the temperature control in the process was accessible to operators, and when they experienced difficulties in injection, they increased the temperature in the oven, to make the metal more fluid. This incorrect procedure also helped the nozzle to lose hardness, which was reflected in a more pronounced wear on the inner channel. In this phase, still preliminary, the flow of material inside the nozzle was studied, verifying that the abrupt change in section of the hole did not help the metal to flow in the best way towards the mould. This change can be observed in more detail in the following Figure 3.

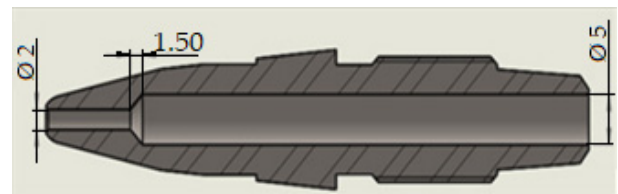

Figure 3. Original zamak injection nozzle inner channel design.

The change in section diameter is quite significant, from 5 mm to 2 mm, at the tip of the injection nozzle. Injection nozzles used over several days in the injection of zamak were analysed, being cut in the manner previously described. The original nozzles did not undergo nitriding, being only quenched, this would impact severely the nozzle's wear performance. Various samples of these nozzles were analysed, in the following images, Figure 4 and Figure 5 the wear

sustained by these nozzles after roughly 15 days of use, at a rate of 500 injections per hour is presented.

It can be seen in Figure 4. and Figure 5. that the nozzles sustained severe wear in the inner channel after a short usage. The wear was mainly localized slightly before the abrupt change in section. Nozzles also seem to have suffered some deformation in their overall shape (Figure 5.). Another problem reported with the original nozzle's design, was that the abrupt change in section in the outer nozzle (Figure 6), would promote a stress concentration in this area, eventually leading to fracture of the nozzle.



Figure 4. Sample 1 - Wear sustained by injection nozzles (original design) after 11 days of use, at an injection rate of 500 injections per hour.



Figure 5. Sample 2 - Wear sustained by an injection nozzle (original design) after 17 days of use, at an injection rate of 500 injections per hour.

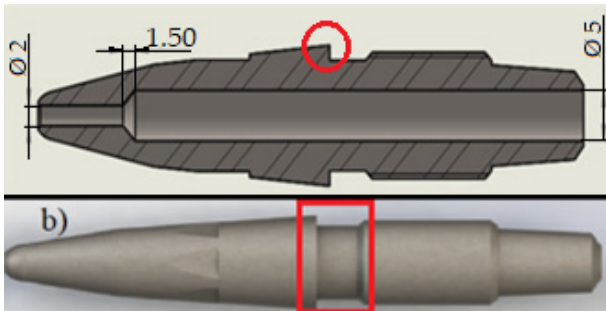

Figure 6. Cross-sectional view (a) and 3D model (b) of the original nozzle, with the abrupt external change in section highlighted in red

3. RESULTS AND DISCUSSION

In this section, the various iterations of the injection nozzle are going to be presented. Furthermore, the various steps of the Action-Research Methodology are going to be described, in the context of the conducted work, from "Action-Planning" to the last step, "Monitoring/Outcomes".

As seen from the first step ("Diagnosis") described in the previous section, many problems with the regular injection nozzle were found, these problems were analysed and solutions to them started to be formulated. These solutions and their impact on the injection

nozzle's performance are going to be described in the next section.

3.1 First Iteration

In this section the first iteration of the injection nozzle is going to be presented, starting in the second step of Table 1, "Action-Planning", referring to the possible solutions for the problems associated with the use of the regular injection nozzle.

Action-Planning (Step 2):

Changes to the nozzle design were implemented to correct the previously presented problems, including the heat-treatment of the nozzle's material (nitriding). The inner channel was redesigned, removing the abrupt change in diameter (5 mm to 2 mm). The section change would be in the same place (hot zone) as the original nozzle; however, it would vary from 3 mm to 1.80 mm. This smaller transition would improve the flow of the material within the nozzle, thus preventing the premature wear of this area. Furthermore, a change in the outer nozzle design was also implemented, addressing the problem depicted in Figure 6: a fillet was done at this location to better distribute the stresses built up at this location. The changes to the nozzle's design are depicted in Figure 7, where the reworked inner channel and the fillet can be observed.

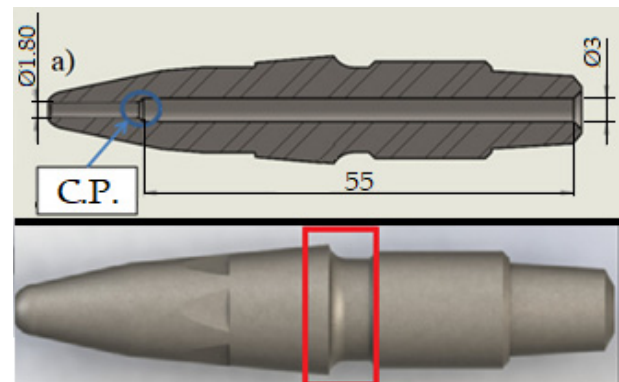

Figure 7. Cross-sectional view of the improved nozzle's inner channel, with the choke point (CP) identified (a) and 3D model of the filleted area, highlighting this area with a red square(b)

Implementation and Evaluation (Step 3 and 4):

This subsection regards the implementation of the design changes to the nozzles and its evaluation, these are steps 3 and 4 of the Action-Research Methodology adopted for this work.

An injection nozzle was produced with these changes and subsequently tested and analysed in the same manner as the first nozzle. Inner channel wear was evaluated on nozzles that were employed in the injection process. The heat-treatment and improved design produced incredible results in terms of wear performance. Nozzle internal wear is depicted in the following Figure 8. and Figure 9.

Monitoring/Outcomes (Step 5):

Nozzles were analysed after roughly 50 days of use and as seen from Figure 8., the wear presented is considerably less severe than that of the original nozzle. The wear is still located before the choke point (CP),

however, there is very little wear after many days of use (as compared to the wear sustained by the original nozzles after 15 days of use). As seen in Figure 4 and Figure 5, the wear is initially caused by the abrupt change in section size, resulting in a “pooling” of material in the area that sustains more wear, which in turn promotes the wear of that same area. With this more attenuated change in section size of the inner channel, the materials flow to the mold smoothly, thus significantly reducing the wear of this area. Moreover, it was found that the temperature used in the nozzles was higher than the used in the nitriding treatment. Thus, the nitriding hardening effect, as well as reduced adhesion were compromised. This implied a reduction of the temperature used in the process to values 60oC below the nitriding treatment, which is perfectly enough to melt the zamak alloy. Furthermore, the change in the outer design promoted a longer service life of these injection nozzles, proving that these changes were a big improvement over the original nozzles. This is due to a careful analysis of the previous nozzle, highlighting the problems and planning/implementing possible solutions, and as seen in this case, with some success.

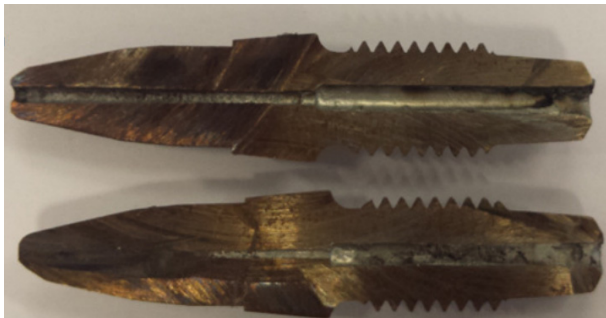

Figure 8. Sample 1 – Wear sustained by injection nozzle (first iteration) after 59 days of use, at an injection rate of 500 injections per hour.



Figure 9. Sample 2 – Wear sustained by injection nozzle (first iteration) after 47 days of use, at an injection rate of 500 injections per hour.

Despite the significant improvement of the nozzles’ wear behavior, there was still room for improvement of the nozzles design. It was noted that the time for the nozzle to reach the desired temperature was still high, and there were some problems regarding zamak refluxes in the nozzle’s cold zone. At this point, with the knowledge collected from the implementation of the new nozzles design, a new iteration for the injection nozzle was developed.

3.2 Second iteration

The last step presented in Table 1 acts as a connection to the beginning of the next cycle (iteration), as it

provides information on the (still) present problems of the injection nozzle. Therefore, this iteration (as seen in the first one) will start with the planning of solutions to the problems found from Step 5 in the previous iteration.

Action-Planning (Step 2)

To solve the presented problems, the inner channel and nozzle shape were, once again, redesigned. To prevent reflux problems in the cold zone of the inner channel, the section variation was placed in this area. The inner channel diameter varies from 3 mm to 1.80 mm, as this value produced good results in terms of wear in the first iteration. This design change is depicted in Figure 10.

As previously mentioned, the time required to heat the nozzle could still be optimized, for this, the distance between the electrical resistance and the inner channel should be reduced (to promote a faster heating). Furthermore, the outer design caused an uneven heating of the nozzle. To try and correct this, the outer design was changed from a conical design, as seen in Figure 11, to a more uniform, straight design seen in Figure 12.

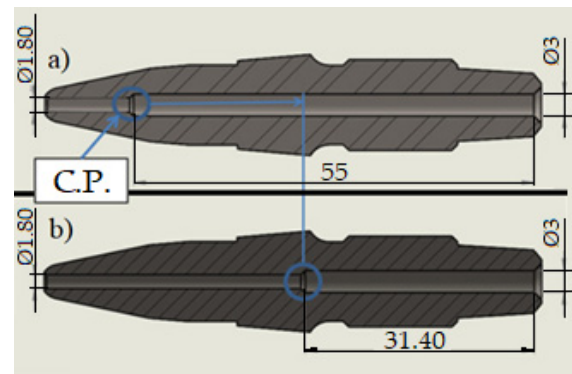

Figure 10. Position of the injection nozzle CP (choke point) at two different locations, first iteration nozzle (hot zone) (a) and second iteration nozzle (cold zone) (b)

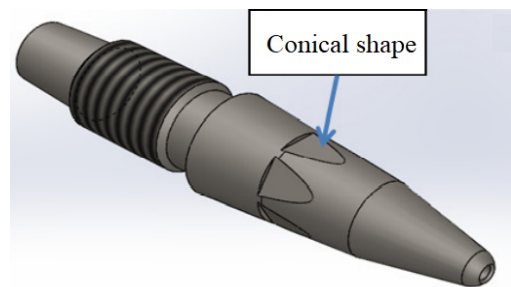

Figure 11. First iteration design of the injection nozzle (outer design)

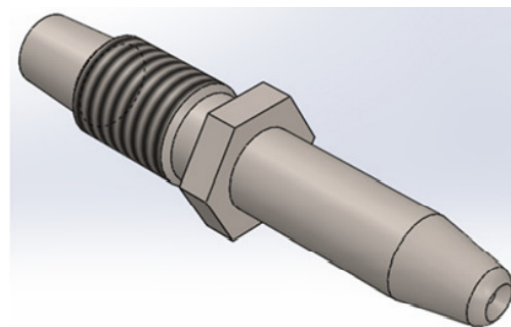

Figure 12. Second iteration design of the injection nozzle (outer design)

The design depicted in Figure 11. reduced the distance from the resistance to the inner channel by 1.25 mm (from 8.25 mm to 7 mm). A uniform design also promoted an even and faster heating of the nozzle. Furthermore, the second iteration design enabled a better accommodation for the resistance that is used to heat the nozzles. Even promoting a smoother resistance setup. The two nozzle designs with mounted resistances can be observed in Figure 13.

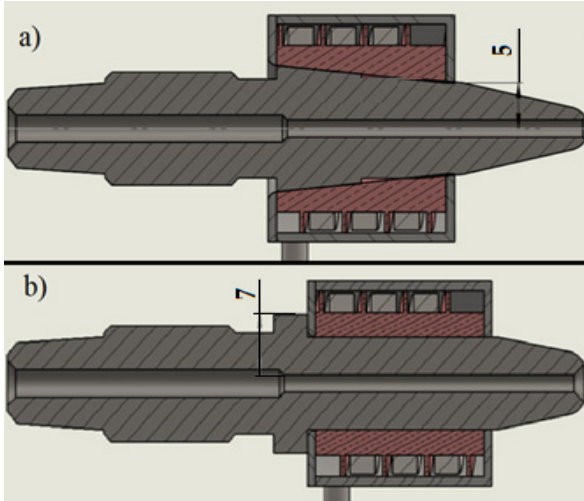

Figure 13. First iteration nozzle with assembled electrical resistance (a) Second iteration nozzle with assembled electrical resistance (b)

Implementation and Evaluation (Step 3 and 4)

This new design was tested as the previously presented one, being implemented in the fabrication of injection nozzles. These nozzles were employed in the injection of zamak during several days and were subsequently analysed. Figure 14. depicts a sample obtained from a nozzle employed for 63 days, at the same injection rate as the previously presented ones (500 injections per hour).

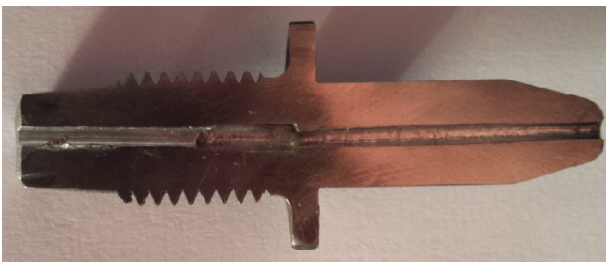

Figure 14. Sample 1 – Wear sustained by injection nozzle (first iteration) after 63 days of use, at an injection rate of 500 injections per hour.

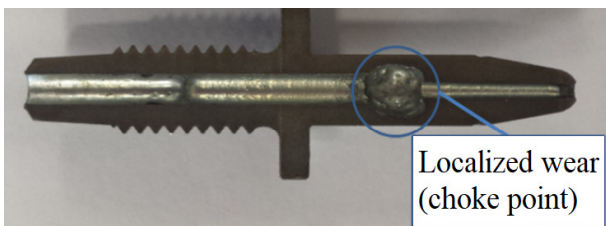

Figure 15. Wear sustained at the choke point by a second iteration injection nozzle (after intense use)

It is observed that even after 63 days of work, the nozzle presents very little wear, proving that the chosen

design still confers excellent wear resistance to the injection nozzles. The change in the channel section being at a different location, did not negatively impact the wear behaviour of these nozzles when compared to the first iteration. As seen in the first iteration, the wear was localized on the section transition zone, as observed in Figure 15.

Monitoring/Outcomes (Step 5)

The redesign of the inner channel corrected the material reflux problems in the cold zone and did not impact the wear behaviour of the nozzle, proving to be a successful change. The change to the outer designed promoted a faster and homogeneous heating of the nozzle, due to the reduced thickness (distance from the resistance to the nozzle's inner channel) and a uniform nozzle section. This iteration produced highly satisfactory results, both in terms of wear behaviour, tool-life, and improvement of the injection process by optimizing nozzle heating. Thus, it can be highlighted as outcomes:

- The change in section of the inner channel should be moderated, avoiding the creation of reflux and turbulence into the channel;

- The temperature of the molten metal should be cared, avoiding being close or surpass the temperature used in the nitriding process, because higher temperatures will eliminate the hardening effect, as well as the anti-adhesion effect of the nitriding treatment. At this point a limit of 60oC below the nitriding process has been established;

- The reduction of the wall section in the posterior part of the nozzle, where the electrical resistance is assembled, will improve the heating process of the channel, letting the metal flow smoothly;

- The external linear design of the nozzle will make easier the assembly/disassembly of the electrical resistance when one of the needs to be replaced, but the other can continue in service in the posterior part of the nozzle.

The topics constitute transferrable knowledge that can be extract from this work to other similar situations, where wear and the lifespan of components are degrading the competitiveness of a certain manufacturing process.

The final chosen design (Figure 16.) was successfully implemented in the die casting of zamak. A significant improvement of the nozzle's tool-life was registered, effectively solving the problem of the premature failure of the tools used in this process. No more iterations were made at this point, as the obtained results were highly satisfactory.



Figure 16. Chosen design for the injection nozzle (second iteration).

4. CONCLUSIONS

In this work the active-research methodology was implemented as a means to improve the design of injection nozzles used in the die casting of zamak. This method enabled the continuous improvement of this component, proving to be useful when applied to situations such as the one depicted in this paper.

There was an initial analysis of the problem (diagnostic), by testing the original nozzles. From the analysis, the problems were identified and solutions to overcome these problems were devised. These were then implemented and studied, enabling for more improvements based on these changes. In this work, two iterations were made to the injection nozzles, achieving better results with each iteration.

In the first iteration a reduction of the abrupt change in section of the inner channel was performed, as a means to reduce the wear sustained by the nozzle during the injection of zamak. The outer design was also changed, by inserting a fillet on a section that had an abrupt change in diameter. This action reduced the stresses concentration in this area, effectively increasing tool life. However, there were some problems registered during the process, namely material reflux in the cold zone of the inner channel, and slow and uneven heating of the nozzle. Following the action-research methodology, ways to correct these problems were devised and subsequently implemented, creating a second iteration of the tool.

For the second iteration, the section reduction zone was brought back to the cold area, to mitigate the material reflux occurring in this area (using the first iteration nozzle). Furthermore, this change did not negatively impact the wear behaviour of the nozzle. Regarding the heating problems, in order to promote a faster and homogeneous heating, the nozzle's outer design was changed from a conical shape to a straight and thinner shape. This reduced the distance from the resistance to the nozzle's inner channel, thus, heating the material faster. The new shape also brought some advantages in terms of resistance setup, enabling for a faster assembly of the resistance onto the injection nozzle.

At this point, no more iterations were made as the results were considered satisfactory. The new nozzle knew a significant improvement over the original one in all regards: suffering significantly less wear; faster and more homogeneous heating of the nozzle; overall safety of the process (use of electrical resistances). It is also important to note that, the most influential factors that need to be given special attention in the development of these injection nozzles are:

- Inner channel section variation;
- Exterior design influence on the nozzle's performance;
- Electrical resistance positioning;
- Choke point (inner channel) position.

This work also highlights the usefulness of the active-research methodology, in applications of machine components that are subject to severe wear and, especially, in cases where a pure scientific approach is not viable/possible.

In terms of future works, a model using simulation where the process parameters and mechanical and physical properties of the nozzles can be input, and the expected lifespan of the nozzle can be calculated, should be developed. This will help the industrial and maintenance managers to predict the regular maintenance operations, helping in the planning of nozzle change, optimizing its working life and avoiding safety problems.

ACKNOWLEDGMENTS

The authors would like to thank Mr. Mário Cardoso from FicoCables, Lda. for his continuous support, proving interesting challenges for applied research. Authors would like to thank Ing. Fátima Andrade due to her help in preparing the samples and collecting images in the optical microscope. Authors would also thank INEGI - Instituto de Ciência e Inovação em Engenharia Mecânica e Engenharia Industrial, Porto, Portugal, due to its continuous support.

REFERENCES

- [1] Araújo, W.F.S., Silva, F.J.G. and Campilho R.: Manufacturing cushions and suspension mats for vehicle seats: a novel cell concept. Springer - Int. J. Adv. Manuf. Tech., Vol. 90, No. (5-8), pp. 1539-1545, 2017. doi: 10.1007/s00170-016-9475-6.
- [2] Rosa, C., Silva, F.J.G., Ferreira, L.P., Pereira, T. Gouveia R.: Establishing Standard Methodologies to Improve the Production Rate of Assembly Lines Used for Low Added-Value Products; Elsevier - Procedia Manuf., Vol. 17, pp. 555-562, 2018. doi: 10.1016/j.promfg.2018.10.096.
- [3] Dengiz, B., Tansel, Y. and Belgin, O.: A meta-model based simulation optimization using hybrid simulation-analytical modeling to increase the productivity in automotive industry; Elsevier - Math. Comput. Simul., Vol. 120, pp. 120-128, 2016. doi:10.1016/j.matcom.2015.07.005
- [4] Grodzicki, M.J. Skrzypek, J.: Cost-competitiveness and structural change in value chains - vertically-integrated analysis of the European automotive sector; Elsevier - Struct. Change Econ. Dyn., Vol. 55, pp. 276-287. doi: 10.1016/j.strueco.2020.08.009
- [5] Matijevic, D.V. and Popovic, V.M.: Overview of the Modern Contributions in Vehicle Noise and Vibration Refinement with Special Emphasis on Diagnostics; FME Trans., Vol. 45, pp. 448-458, 2017. doi:10.5937/FMET1703448M.
- [6] Concilio, A., De Simone, M.C., Rivera, Z.B. and Guida, D.: A New Semi-Active Suspension System for Racing Vehicles; FME Trans., Vol. 45, pp. 578-584, 2017. doi:10.5937/fmet1704578C.
- [7] Sathickbasha, K., Selvakumar, A.S., Sai, B.M.A. and Surya, R.B.: Effect of Steel Family Fibers on Friction and Stiction Behavior of Brake Pads; FME Trans., Vol. 47, pp. 856-864, 2019. Doi: doi:10.5937/fmet1904856S.
- [8] Costa, M.J.R., Gouveia, R.M., Silva, F.J.G. and Campilho, R.D.S.G.: How to solve quality prob-

- lems by advanced fully-automated manufacturing systems; Springer – Int. J. Adv. Manuf. Tech., Vol. 94, No. (9-12), pp. 3041-3063, 2018. doi: 10.1007/s00170-017-0158-8.
- [9] Martins, M., Godina, R., Pimentel, C., Silva, F.J.G., and Matias, J.C.O.; A Practical Study of the Application of SMED to Electron-beam Machining. In Automotive Industry; Elsevier - Procedia Manuf., Vol. 17, pp. 647-654, 2018. doi: 10.1016/j.promfg.2018.10.113.
- [10] Jan, M., Tomás, K., Jozef, K. and Iveta, C.: Design of the Crusher for Plastic and Rubber Waste Produced in Automotive Industry; FME Trans., Vol. 49, pp. 734-739, 2021. doi: doi:10.5937/fme2103734M.
- [11] Stadnicka, D. and Antonelli D.: Application of Value Stream Mapping and Possibilities of Manufacturing Processes Simulations in Automotive Industry; FME Trans., Vol. 43, pp. 279-286, 2015. doi:10.5937/fmet1504279S.
- [12] Rosa, C., Silva, F.J.G. and Ferreira, L.P.: Improving the Quality and Productivity of Steel Wire-rope Assembly Lines for the Automotive Industry; Elsevier - Procedia Manuf., Vol. 11, pp.1035-1042, 2017. doi: 10.1016/j.promfg.2017.07.214.
- [13] Nguyen, H.G., Kuhn, M. and Franke, J.: Manufacturing automation for automotive wiring harnesses; Elsevier – Procedia CIRP, Vol. 97, pp. 379-384, 2021. doi: 10.1016/j.procir.2020.05.254
- [14] Moreira, B.M.D.N., Gouveia, R.M., Silva, F.J.G. and Campilho, R.D.S.G.: A Novel Concept Of Production And Assembly Processes Integration; Elsevier - Procedia Manuf., Vol. 11, pp. 1385-1395, 2017. doi: 10.1016/j.promfg.2017.07.268.
- [15] Villanueva-Rey, P., Belo, S., Quintero, P., Arroja, L. and Dias, A.C.: Wiring in the automobile industry: Life cycle assessment of an innovative cable solution; Elsevier – J. Cleaner Prod., Vol. 204, No. 10, pp. 237-246, 2018. doi.org/10.1016/j.jclepro.2018.09.017
- [16] Sanjuan, J.D., Castillo, A.D., Padilla, M.A., Quintero, M.C., Gutierrez, E.E., Sampayo, I.P., Hernandez J.R. and Rahman, M.H.: Cable driven exoskeleton for upper-limb rehabilitation: A design review; Elsevier – Rob. Auton. Syst., Vol. 126, pp. 103445, 2020. doi: 10.1016/j.robot.2020.103445
- [17] Herbin, P. and Pajor, M.: Human-robot cooperative control system based on serial elastic actuator bowden cable drive in ExoArm 7-DOF upper extremity exoskeleton; Elsevier – Mech. Mach. Theory, Vol. 163, pp. 104372, 2021. doi: 10.1016/j.mechmachtheory.2021.104372
- [18] Pinto, H., and Silva, F.J.G.: Optimisation of die casting process in Zamak alloys; Elsevier - Procedia Manuf., Vol. 11, pp. 517-525, 2017. doi: 10.1016/j.promfg.2017.07.145.
- [19] Pinto, H., Silva, F.J.G., Martinho, R.P., Campilho, R.D.S.G. and Pinto, A.G.: Improvement and validation of zamak die casting moulds; Elsevier - Procedia Manuf., Vol. 38, pp. 1547-1557, 2019. doi: 10.1016/j.promfg.2020.01.131.
- [20] Pinto, G.; Silva, F.J.G.; Baptista, A.; Campilho, R.D.S.G. and Viana, F.: Investigations on the Oxidation of the Zn-coated Steel Cables; FME Trans., Vol. 49, pp. 587-597, 2021. doi:10.5937/fme2103587P.
- [21] Pinto, G., Silva, F.J.G., Baptista, A., Fecheira, J.S., Campilho, R.D.S.G. and Viana, F.: Studying the ZnO formation in coated steel wire ropes for the automotive industry; Elsevier - Procedia Manuf., Vol. 51, pp. 912-919, 2020. doi: 10.1016/j.promfg.2020.10.128.
- [22] Nunes, V., Silva, F.J.G., Andrade, M.F., Alexandre, R. and Baptista, A.P.M.: Increasing the lifespan of high-pressure die cast molds subjected to severe wear; Elsevier – Surf. Coat. Technol., Vol. 332, pp. 319-331, 2017. doi: 10.1016/j.surfcoat.2017.05.098.
- [23] Tai, C.C.; Li, J.C.; A runner-optimization design study of a die-casting die; Elsevier - J. Mater. Process. Technol., Vol. 84, pp. 1-12, 1998. doi: 10.1016/S0924-0136(98)00031-4.
- [24] Cleary, P.W., Ha, J., Prakash, M. and Nguyen, T.: Short shots and industrial case studies: Understanding fluid flow and solidification in high pressure die casting; Elsevier - Appl. Math. Model., Vol. 34, No. 8, pp. 2018-2033, 2010. doi: 10.1016/j.apm.2009.10.015.
- [25] Kong, L.X., She, F.H., Gao, W.M., Nahavandi, S. and Hodgson, P.D.: Integrated optimization system for high pressure die casting processes; Elsevier - J. Mater. Process. Technol., Vol. 201, pp. 629-634, 2008. doi: 10.1016/j.jmatprotec.2007.11.250.
- [26] Silva, F.J.G., Campilho, R.D.S.G., Ferreira, L.P. and Pereira, M.T.: Establishing Guidelines to Improve the High-Pressure Die Casting Process of Complex Aesthetics Parts, in: Transdisciplinary Engineering Methods for Social Innovation of Industry 4.0, M. Peruzzini et al. (Eds.), pp. 887-896, 2018. doi:10.3233/978-1-61499-898-3-887.
- [27] Page, M.A.M., Weidenfeller, B. and Hartmann, S.: Influence of temperature and aging on the thermal diffusivity, thermal conductivity and heat capacity of a zinc die casting alloy; Elsevier – J. Alloys Compd., Vol. 786, pp. 1060-1067, 2019. doi: 10.1016/j.jallcom.2019.01.371
- [28] Page, M.A.M. and Hartmann, S.: Experimental characterization, material modeling, identification and finite element simulation of the thermo-mechanical behavior of a zinc die-casting alloy; Elsevier – Int. J. Plast., Vol. 101, pp. 74-105. doi: 10.1016/j.ijplas.2017.10.010
- [29] Shanmugasundar, G., Sabarinath, S.S., Babu, K.R. and Srividhya, M.: Analysis of occupational health and safety measures of employee in material manufacturing industry using statistical methods; Elsevier – Mater. Today Proc., In press, Corrected Proof, Available online 7 January 2021. doi: 10.1016/j.matpr.2020.11.296

- [30] Ramaganes, M., Jayasuriyan, R., Rajpradeesh, T., Bathrinath, S. and Manikandan, R.: Ergonomics hazard analysis techniques- A technical review; Elsevier – Mater. Today Proc., In press, Corrected Proof, Available online 9 March 2021. doi: 10.1016/j.matpr.2021.02.329
- [31] Muller, R., Vette, M. and Scholer, M.: Robot Workmate: A Trustworthy Coworker for the Continuous Automotive Assembly Line and its Implementation; Elsevier – Procedia CIRP, Vol. 44, pp. 263-268, 2016. doi: 10.1016/j.procir.2016.02.077
- [32] Magalhães, A.J.A., Silva, F.J.G. and Campilho, R.D.S.G.: A novel concept of bent wires sorting operation between workstations in the production of automotive parts; Springer - J. Braz. Soc. Mech. Sci. & Eng., Vol. 41, pp. 25, 2019. doi: 10.1007/s40430-018-1522-9.
- [33] Mayyas, A., Qattawi, A., Omar, M. and Shan, D.: Design for sustainability in automotive industry: A comprehensive review; Elsevier – Renew. Sust. Energ. Rev., Vol. 16, pp. 1845-1862, 2012. doi: 10.1016/j.rser.2012.01.012.
- [34] Yin, G., Zhu, Z., Gong, H., Lu, Z., Yong, H., Liu, L. and He, W.: Flexible punching system using industrial robots for automotive panels; Elsevier – Rob. Comput. Integr. Manuf., Vol. 52, pp. 92-99, 2018. doi: 10.1016/j.rcim.2017.11.002
- [35] Silva, F.J.G. and Gouveia, R.M. *Cleaner Production – Toward a better future*, Springer Nature, Switzerland, 2020. ISBN: 978-3-030-23164-4.
- [36] Santos, J., Gouveia, R.M. and Silva, F.J.G.: Designing a new sustainable approach to the change for lightweight materials in structural components used in truck industry; Elsevier – J. Clean. Prod., Vol. 164, pp. 115-123, 2017. doi: 10.1016/j.jclepro.2017.06.174.
- [37] Long, A., Thornhill, A., Armstrong, C. and Watson, D.: Predicting die life from die temperature for high pressure dies casting aluminum alloy; Elsevier - Appl. Therm. Eng., Vol. 44, pp. 100-107, 2012. doi: 10.1016/j.applthermaleng.2012.03.045.
- [38] Gulizia, S., Jahedi, M.Z. and Doyle, E.D.: Performance evaluation of PVD coatings for high pressure die casting; Elsevier – Surf. Coat. Technol., Vol. 140, pp. 200-205, 2001. doi: 10.1016/S0257-8972(01)01037-4.
- [39] Martins, R., Pereira, M.T., Ferreira, L.P., Sá, J.C. and Silva, F.J.G.: Warehouse operations logistics improvement in a cork stopper factory; Elsevier - Procedia Manuf., Vol. 51, pp. 1723-1729, 2020. doi: 10.1016/j.promfg.2020.10.240.

**УНАПРЕЂЕЊЕ ДИЗАЈНА МЛАЗНИЦА
КОРИШЋЕНИХ У ПОСТУПКУ КАЛУПНОГ
ИЗЛИВАЊА ЗАМАК МАШИНОМ ПОД
ВИСОКИМ ПРИТИСКОМ**

**Ф.В.Ц. Соуза, Ф.Ј.Г. Силва, Ј.П. Ферейра,
Р.Д.С.Г. Кампило, Т. Перейра, Е. Брага**

Убризавање лаких легура је захтевна инжењерска активност јер треба да одржава индустријску конкурентност. Високе температуре у процесу производње изазивају интензивно хабање компонената, што тражи непрекидно побољшање поступка. Циљ рада је решење проблема претераног хабања млазница за убризгавање које се користе у процесу ливења и проблема електричног отпора како би се продужио радни век млазница и индустријска конкурентност при изливању јефтених делова замак машином у аутомобилској индустрији. За решење проблема претераног хабања млазница за убризгавање коришћен је метод акционог истраживања који је преко неколико итерација омогућио да се дизајнира побољшана млазница, па тиме и реши проблем електричног отпора, чиме је продужен радни век компонената, безбедност поступка и преношење и примена знања у другим сличним ситуацијама.